

# THERMOROSSI

## ESSENZA COATING

ITA - MANUALE DI INSTALLAZIONE, USO E MANUTENZIONE.  
FRA - MANUEL D'INSTALLATION, D'UTILISATION ET D'ENTRETIEN.  
ENG - INSTALLATION, USE AND MAINTENANCE GUIDE.  
DEU - INSTALLATIONS-, BETRIEBS- UND WARTUNGSANLEITUNG.  
ESP - MANUAL DE INSTALACIÓN USO Y MANTENIMIENTO.



ITA – Informazioni importanti per la sicurezza ed il corretto funzionamento.  
FRA – À lire impérativement! Informations importantes pour la sécurité et le bon fonctionnement.  
ENG – Must read! Important information for safety and correct operation.  
DEU – Unbedingt lesen! Wichtige Informationen zur Sicherheit und zum sicheren Betrieb.  
ESP – ¡Leer! Informaciones importantes para la seguridad y el correcto funcionamiento.



**INDEX**

1 – INTRODUCTION..... 2  
2 – TECHNICAL CHARACTERISTICS..... 3  
3 – UNPACKING THE CASING ..... 4  
4 – ASSEMBLY OF ESSENZA CASING (instructions only apply to products with sliding feed cover)5  
5 – ASSEMBLY OF ESSENZA CASING (instructions only apply to products with fixed feed cover). 7  
6 – SPARE PARTS ..... 9

**1 – INTRODUCTION**

**1.1 GENERAL GUIDELINES**

This installation, use and maintenance guide is an integral and essential part of the product and must be kept by the user. Before commencing with the installation, use and maintenance of the product, carefully read all the instructions contained in this booklet. All local, national and European regulations regarding the installation and use of the appliance must be met. The Manufacturer recommends carrying out all the maintenance operations described in this manual. Installation, maintenance and repairs must be carried out by professionally qualified personnel, professionally certified according to Decree no. 37 of 22 January 2008 and in compliance with current regulations and in accordance with the instructions provided by the manufacturer of the appliance. In case of repairs only original spare parts supplied by the manufacturer must be used. Incorrect installation or poor maintenance could injure or damage people, animals or things; in this case the manufacturer shall be relieved of all responsibility. Any repairs or actions carried out on any systems, components or internal parts of the appliance, or on any of the accessories supplied with it, that are not specifically authorised by Thermorossi S.p.A, will automatically void the warranty and the manufacturer's responsibility, pursuant to Italian Decree no. 224 of the President of the Republic of 24/05/1988, art. 6/b. Keep this manual in a safe place that is easily accessible to all users. If the appliance is sold or transferred to another user ensure that the guide is handed over with it. If this manual is lost and/or damaged it is mandatory to ask the manufacturer for a replacement copy.

*Thermorossi S.p.A. retains copyright on these service instructions. These instructions may not be reproduced or communicated to third parties or used in any other way without the necessary authorisation.*



**ATTENTION:** The majolica elements are handcrafted so they could contain subtle surface imperfections, crazing or shade variations. The layer of glaze has an expansion factor that is different to that of the majolica tiles which is what causes the hairline cracks. This phenomenon is a natural process and is not a defect. We recommend cleaning the majolica tiles with a dry microfibre cloth. Using moist or wet cleaning cloths would show up the natural crazing even more.

**1.2 SAFETY STANDARDS**



**PERSONAL INJURY**

This safety symbol identifies important messages throughout the manual. Read the information marked by this symbol carefully as non-observance of this message can cause serious injury to persons using the appliance.



**DAMAGE TO PROPERTY**

This safety symbol identifies messages or instructions that are fundamental for the generator to function well. To avoid serious damage to the appliance adhere strictly to these instructions.



**INFORMATION**

This symbol indicates important instructions for good functioning of the generator. If this information is not correctly observed, the performance of the appliance will not be satisfactory.

**1.3 TRANSPORTATION AND STORAGE**

**TRANSPORTATION AND HANDLING**

Take special care to protect all the fragile parts from mechanical impact which could damage them and their correct functioning.

**STORAGE**

The casing must be stored in a humid-free environment and sheltered from the weather; avoid placing the casing directly on the ground. The company is not responsible for damages caused by negligence. It is inadvisable to store the casing for excessively long periods of time.

**2 – TECHNICAL CHARACTERISTICS**

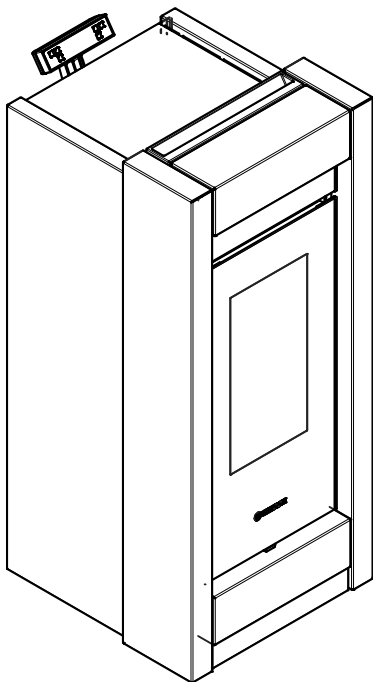

ESSENZA	
Height (mm)	1132
Depth (mm)	596
Width (mm)	490
Net weight of the casing (Kg)	38
Gross weight of the casing (Kg)	48

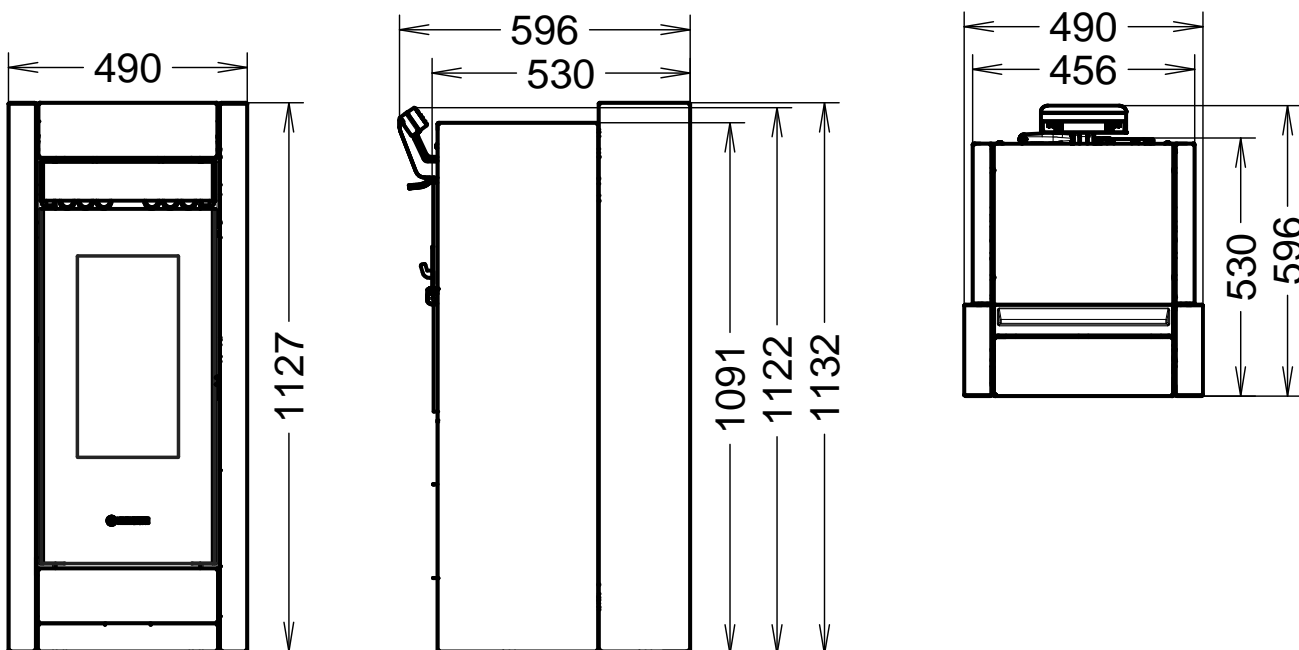

**3 – UNPACKING THE CASING**



To unpack the casing proceed as shown in the figures below.

First of all, after opening the packaging, remove the polystyrene elements (A), (B), (C) and carefully remove the side profiles (D) (Figure 1).

Next, remove the polystyrene element (E), and gently unpack the side panel (H), the bag of fasteners (Q), the bracket (N), the upper profile (O) and the lower profile (P) (Figure 2).

Lastly, remove the polystyrene elements (E), (F), (G) and gently unpack the side panel (R) (Figure 3).



Attention: wear soft cotton gloves when handling the painted casings as they are delicate and must be handled with extreme care. Clean with soft and dry microfibre cloths for delicate surfaces such as lenses, glasses, monitors...



Figura 1



Figura 2

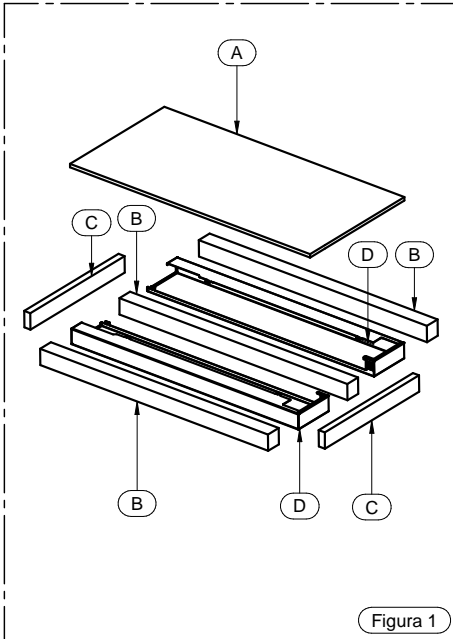

Figura 3

The bag of fasteners (Q) contains the screws illustrated below.

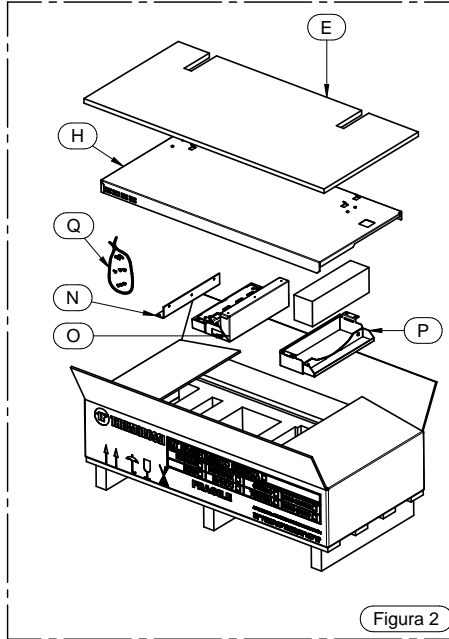

**ATTENTION:**

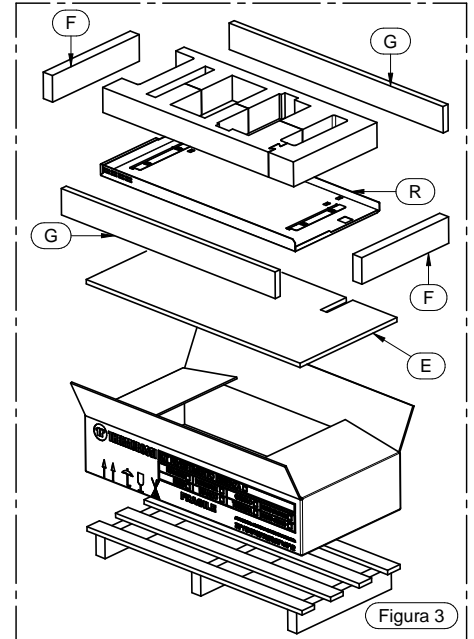
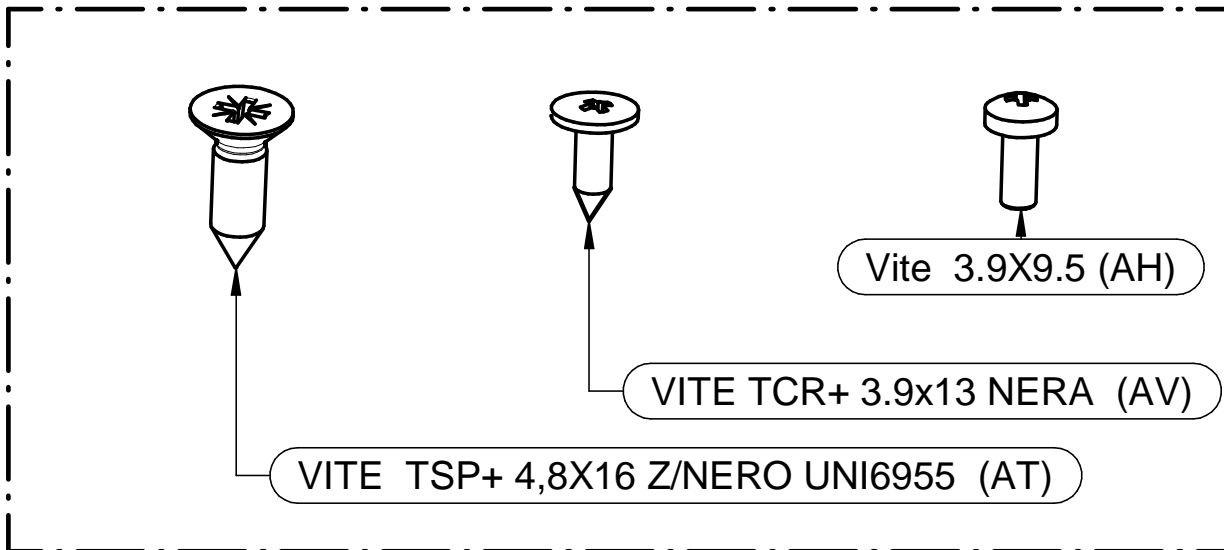
Before proceeding to assemble the casing, adjust the feet of the appliance until the gap between the appliance and the floor is not less than 10 mm.

**ATTENTION:**

Before proceeding to assemble the Essenza casing, make sure that the appliance is disconnected from the electrical power socket and therefore de-energised.

Legenda	Key
Figura	Figure
Vite 3.9x9.5 (AH)	Screw 3.9x9.5 (AH)
VITE TCR+ 3.9X13 NERA (AV)	SCREW TCR+ 3.9X13 BLACK (AV)
VITE TSP+ 4.8X16 Z/NERO UNI6955 (AT)	SCREW TSP+ 4.8X16 Z/BLACK UNI6955 (AT)

**4 – ASSEMBLY OF ESSENZA CASING (instructions only apply to products with sliding feed cover)**

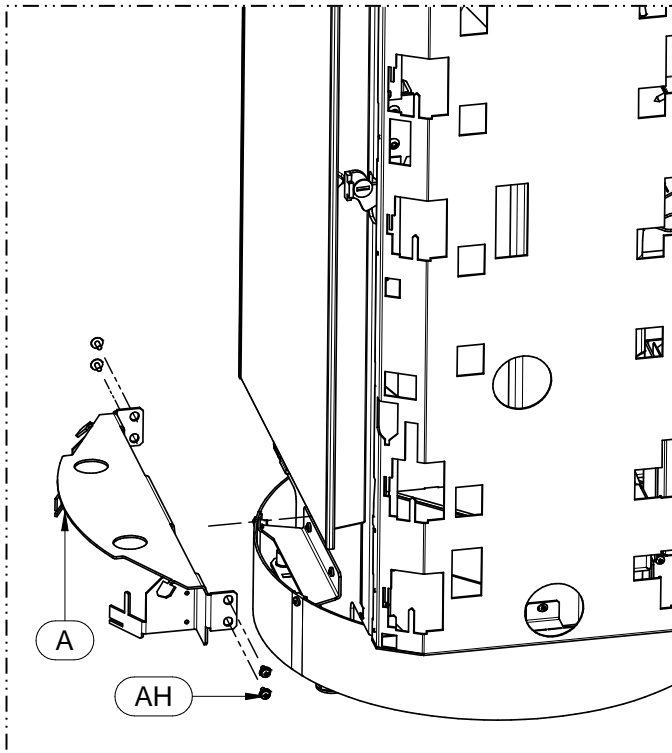

1 – Remove the lower support (A) after undoing the 2 screws (AH) located on both the left side and the right side.

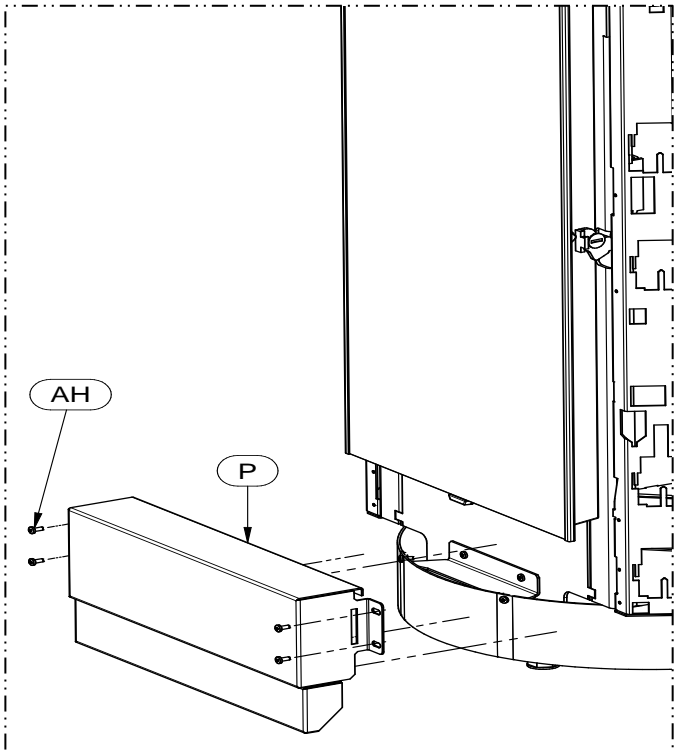

2 – Mount the lower profile (P) using the screws (AH) supplied in the bag of fasteners.

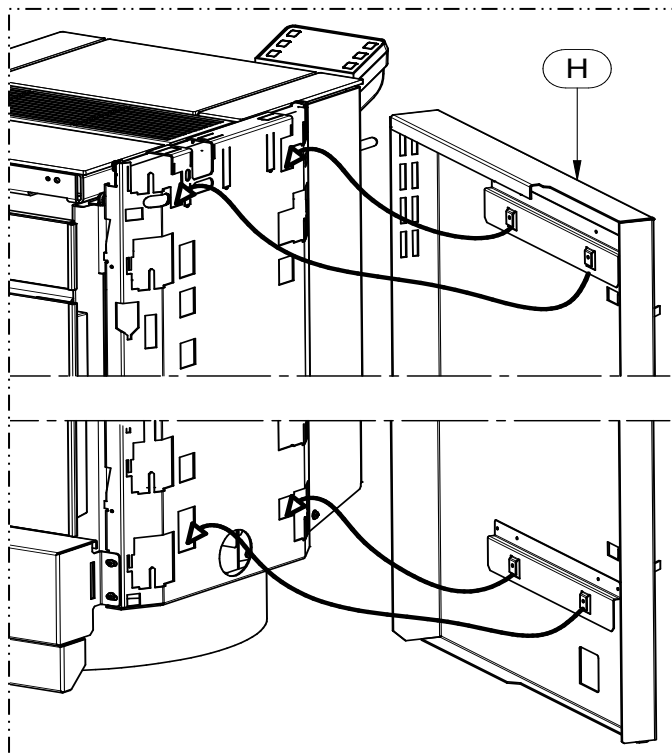

3 – Mount the side panel (H) by inserting the hooks of the panel in the slots provided on the metal plate of the appliance. Carry out the same operation to mount the opposite side panel (R).

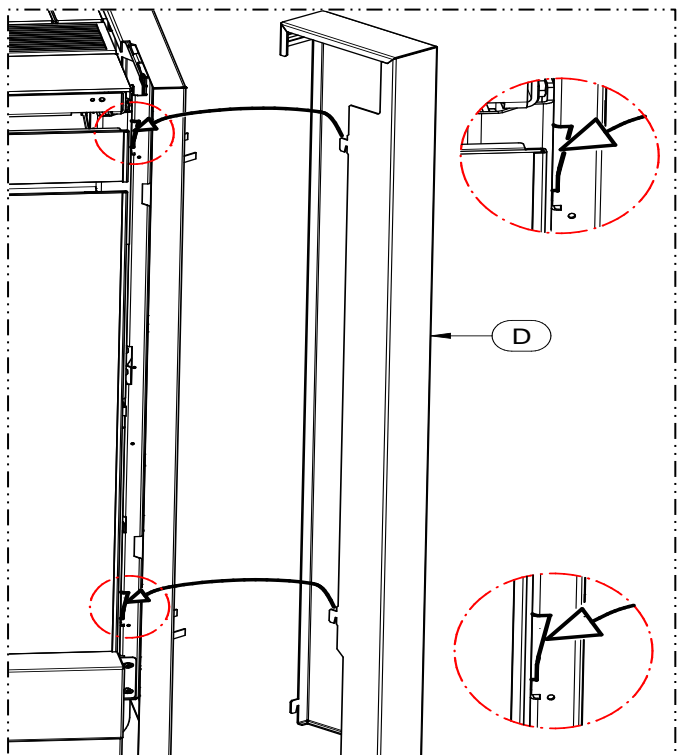

4 – Mount the side profile (D) by inserting the hooks of the profile in the slots provided on the metal plate of the appliance. Carry out the same operation to mount the profile on the opposite side.

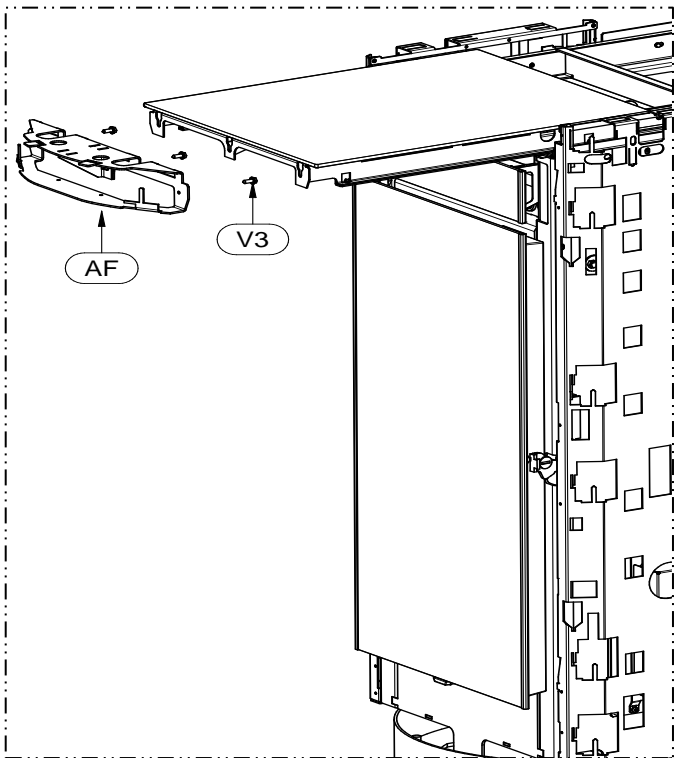

5 – Pull out the tray, undo the 3 screws (V3) and remove the bracket (AF).

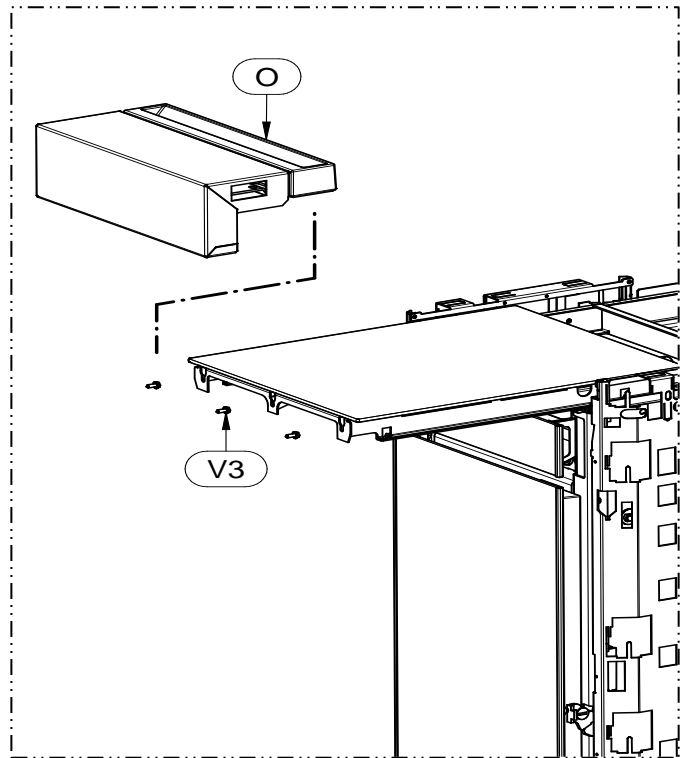

6 – Proceed to mount the upper profile (O) using the 3 screws (V3) that were previously removed.

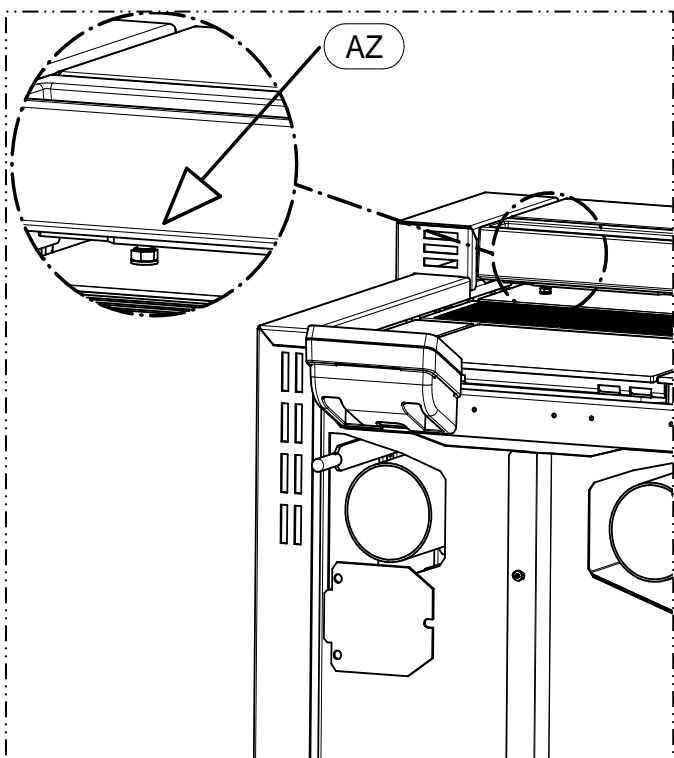

7 – Adjust the mounting foot (AZ) to bring the upper profile to the correct height.



**CAUTION, IMPORTANT:**

Carefully adjust the casing elements, particularly in the area of the handle; make sure that when opening and closing the door it doesn't scrape on the casing and damage it.

**5 – ASSEMBLY OF ESSENZA CASING (instructions only apply to products with fixed feed cover)**

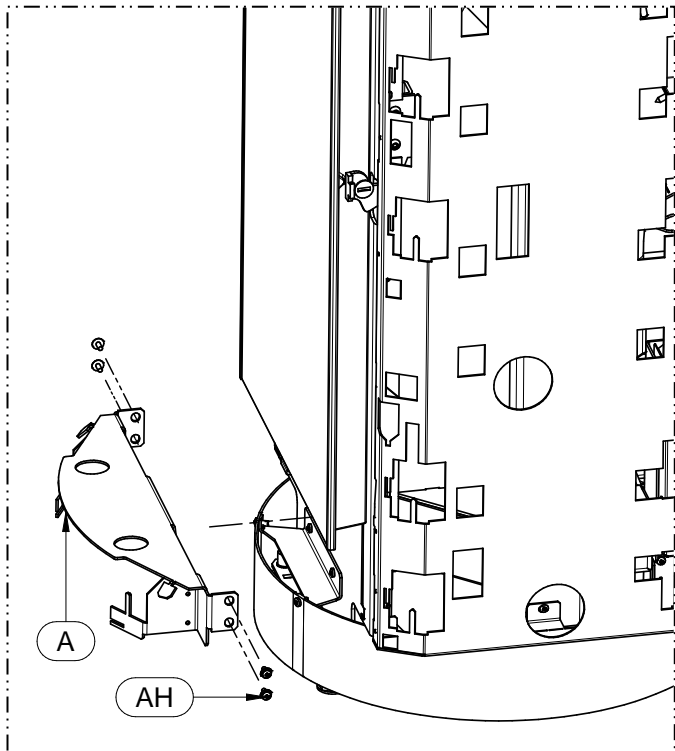

**1** – Remove the lower support (A) after undoing the 2 screws (AH) located on both the left side and the right side.

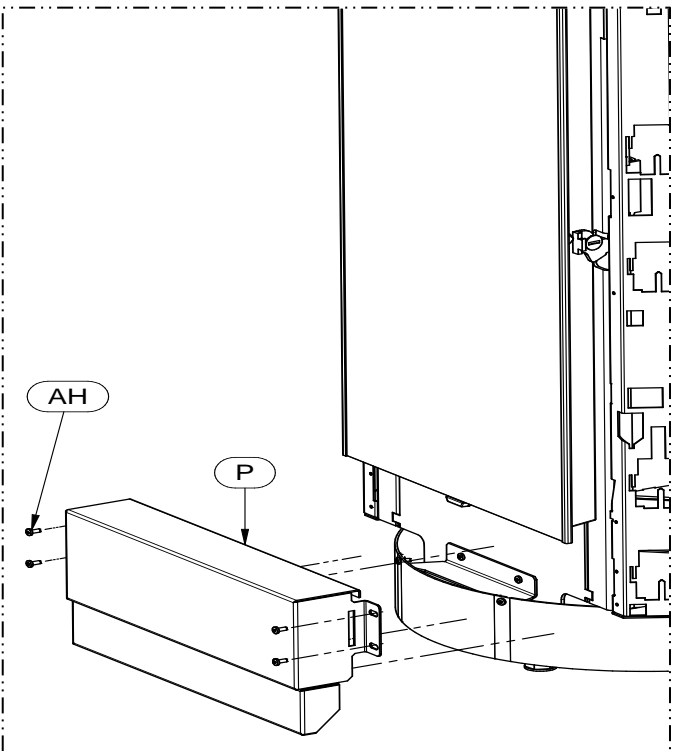

**2** – Mount the lower profile (P) using the screws (AH) supplied in the bag of fasteners.

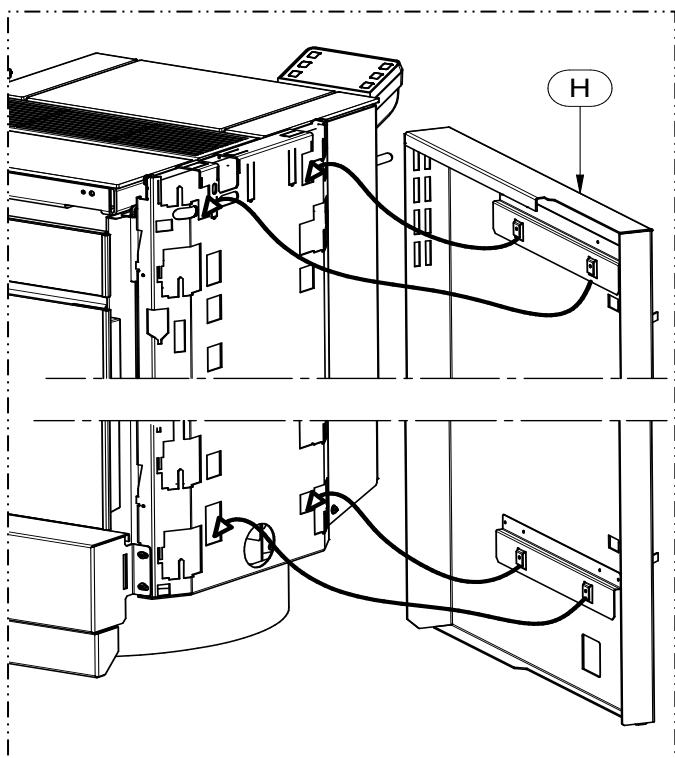

**3** – Mount the side panel (H) by inserting the hooks of the panel in the slots provided on the metal plate of the appliance. Carry out the same operation to mount the opposite side panel (R).

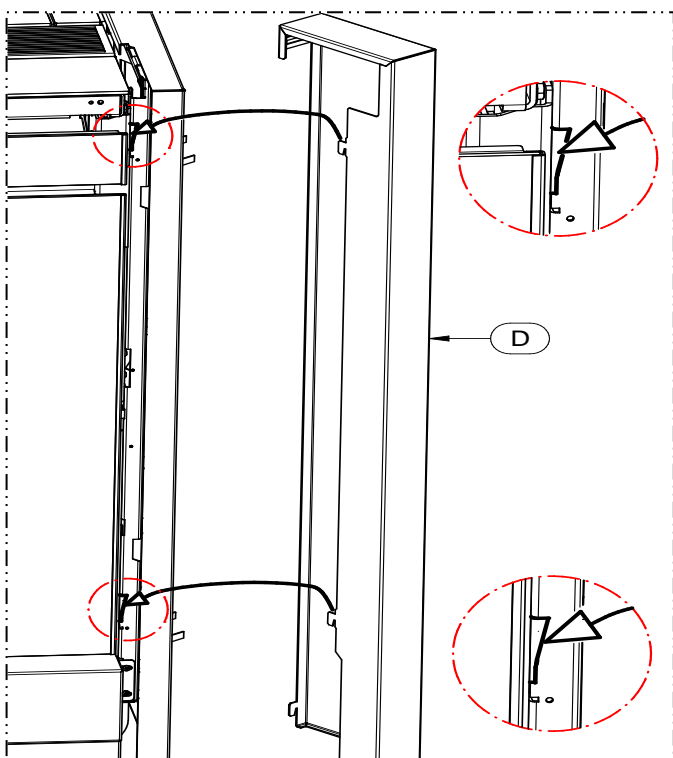

**4** – Mount the side profile (D) by inserting the hooks of the profile in the slots provided on the metal plate of the appliance. Carry out the same operation to mount the profile on the opposite side.



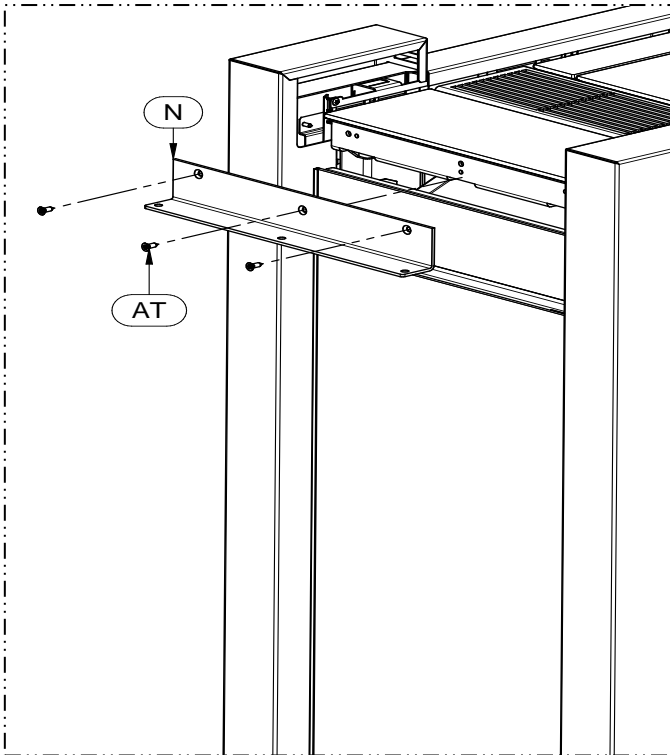

**5** – Mount the bracket (N) using the 3 screws (AT) supplied in the bag of fasteners.

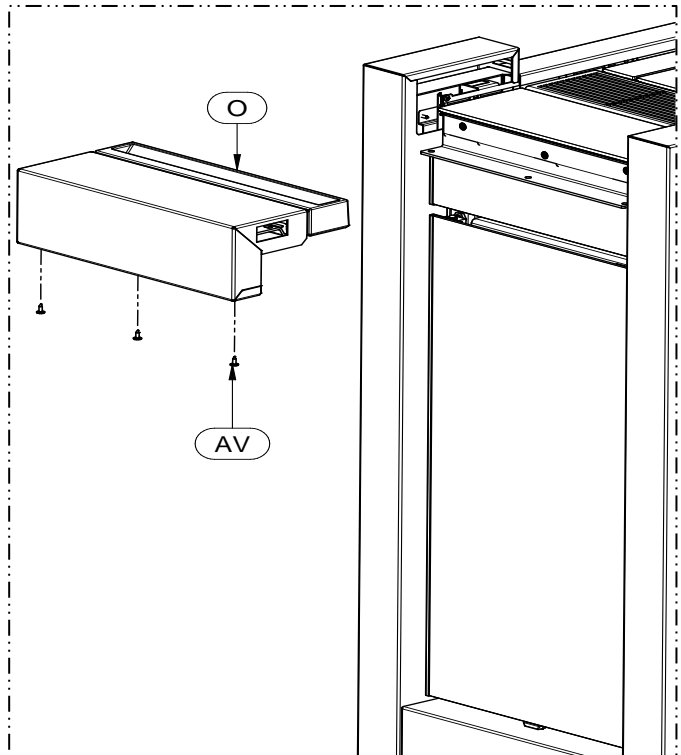

**6** – Proceed to mount the upper profile (O) to the bracket (N), fix it with the 3 screws (AV) supplied in the bag of fasteners.

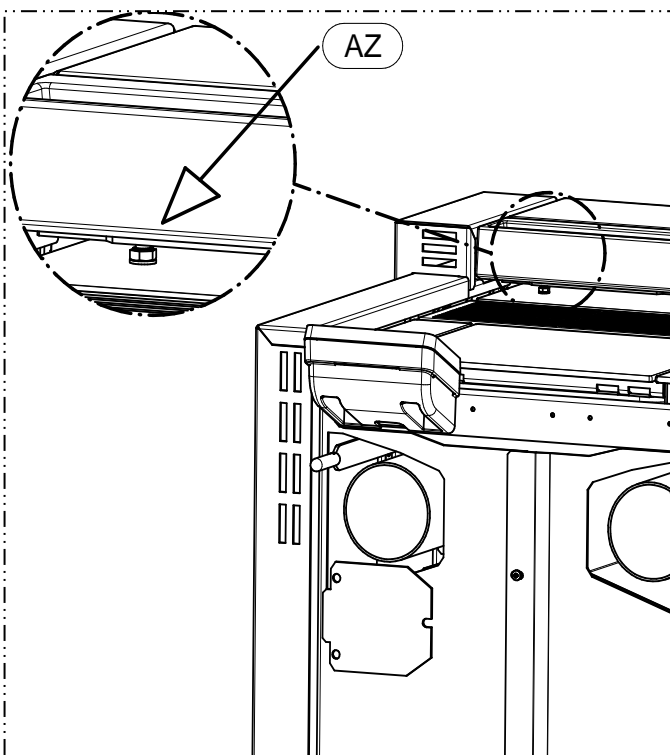

**7** – Adjust the mounting foot (AZ) to bring the upper profile to the correct height.



**CAUTION, IMPORTANT:**

Carefully adjust the casing elements, particularly in the area of the handle; make sure that when opening and closing the door it doesn't scrape on the casing and damage it.

**6 - SPARE PARTS**

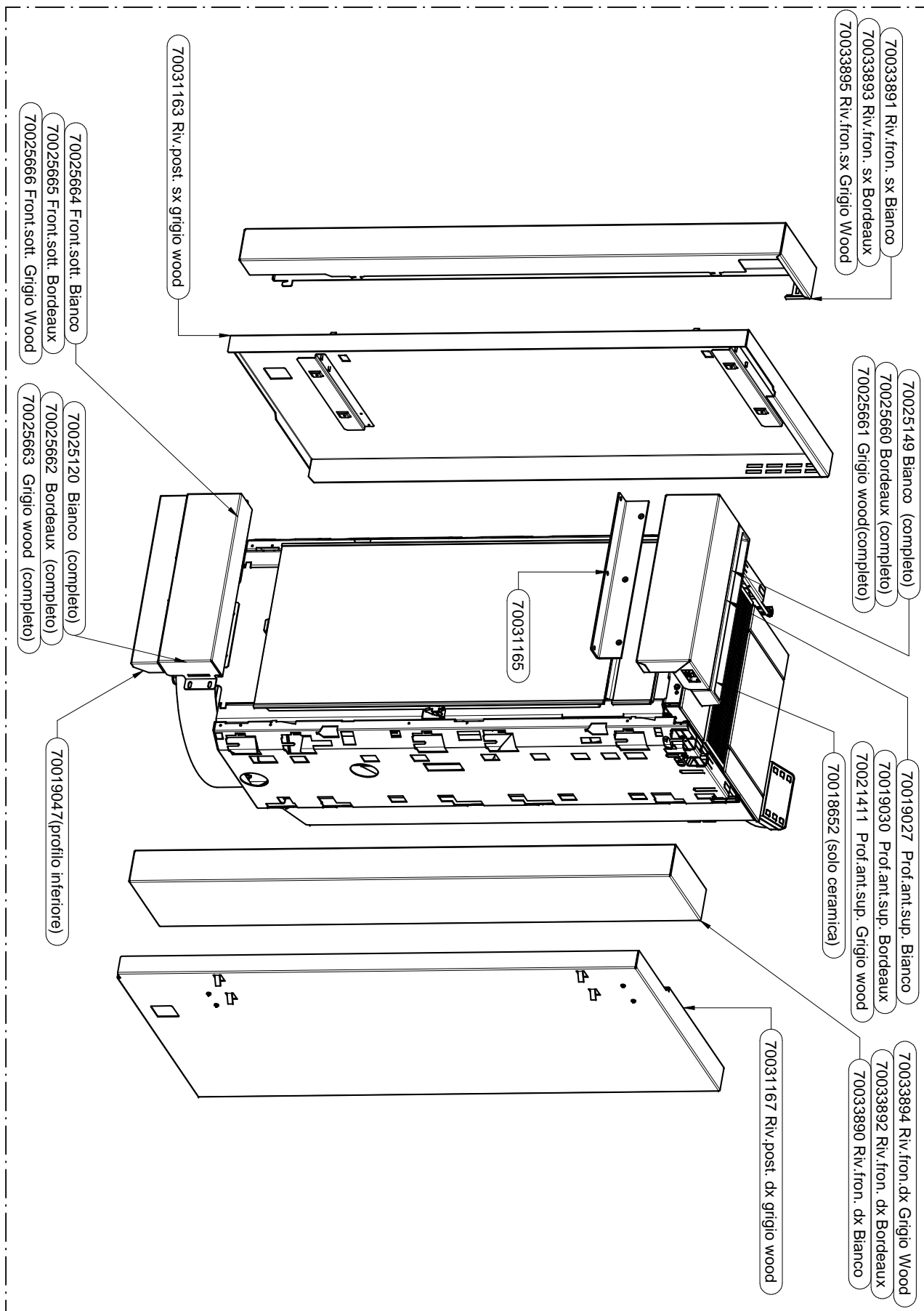

<b>LEGENDA RICAMBI</b>	<b>KEYS TO SPARE PARTS</b>
<b>RIVESTIMENTO ESSENZA</b>	<b>ESSENZA COATING</b>
70033891 Riv.fron. sx Bianco 70033893 Riv.fron. sx Bordeaux 70033895 Riv.fron.sx Grigio Wood	70033891 LH front casing white 70033893 LH front casing bordeaux 70033895 LH front casing grey Wood
70025149 Bianco (completo) 70025660 Bordeaux (completo) 70025661 Grigio wood (completo)	70025149 White (complete) 70025660 Bordeaux (complete) 70025661 Grey Wood (complete)
70019027 Prof.ant.sup. Bianco 70019030 Prof.ant.sup. Bordeaux 70021411 Prof.ant.sup. Grigio wood 70018652 (solo ceramica)	70019027 Front upper profile white 70019030 Front upper profile bordeaux 70021411 Front upper profile grey Wood 70018652 (ceramic only)
70033894 Riv.fron.dx Grigio Wood 70033892 Riv.fron. dx Bordeaux 70033890 Riv.fron. dx Bianco  70031167 Riv.post. dx grigio wood	70033894 RH front casing grey Wood 70033892 RH front casing bordeaux 70033890 RH front casing white  70031167 RH rear casing grey Wood
70031163 Riv.post. sx grigio wood	70031163 LH rear casing grey Wood
70025664 Front.sott. Bianco 70025665 Front.sott. Bordeaux 70025666 Front.sott. Grigio Wood	70025664 Front lower panel white 70025665 Front lower panel bordeaux 70025666 Front lower panel grey Wood
70025120 Bianco (completo) 70025662 Bordeaux (completo) 70025663 Grigio wood (completo)	70025120 White (complete) 70025662 Bordeaux (complete) 70025663 Grey Wood (complete)
70019047(profilo inferiore)	70019047 (lower profile)



**THERMOROSSI** <sup>tr</sup>

*Fire Lovers*

THERMOROSSI S.p.A.

Via Grumolo, 4 (Z.I.) 36011 Arsiero (VI) - ITALY

Fax 0445.741657 - [www.thermorossi.com](http://www.thermorossi.com) - [info@thermorossi.it](mailto:info@thermorossi.it)