

THERMOROSSI

WAIR10

ITA - MANUALE DI INSTALLAZIONE, USO E MANUTENZIONE.
FRA - MANUEL D'INSTALLATION, D'UTILISATION ET ENTRETIEN.
ENG - INSTALLATION, USE AND MAINTENANCE GUIDE.
DEU - INSTALLATIONS, BETRIEBS UND WARTUNGSANLEITUNG.
ESP - MANUAL DE INSTALACIÓN USO Y MANTENIMIENTO.
NL - HANDLEIDING VOOR INSTALLATIE, GEBRUIK EN ONDERHOUD.



ITA - Informazioni importanti per la sicurezza ed il corretto funzionamento.
FRA - À lire impérativement ! Informations importantes pour la sécurité et le bon fonctionnement.
ENG - Must read! Important information for safety and correct operation.
DEU - Unbedingt lesen! Wichtige Informationen zur Sicherheit und zum sicheren Betrieb.
ESP - ¡Leer! Informaciones importantes para la seguridad y el correcto funcionamiento.
NL - Belangrijke informatie voor de veiligheid en de correcte werking.

INDEX

1 – INTRODUCTION..... 4
2 – TECHNICAL CHARACTERISTICS..... 6
3 – GENERAL DESCRIPTION 8
4 – INSTALLATION.....10
5 – USE OF THE APPLIANCE13
6 – CLEANING AND MAINTENANCE16
7 – SMOKE DISCHARGE TUBE AND VENTILATION OF THE ROOMS.....18
8 – PROBLEMS, CAUSES AND SOLUTIONS.....20
9 – CONDITIONS OF WARRANTY20

EU Declaration of Conformity (DoC) / Dichiarazione di Conformità UE (DoC)

Company name:	THERMOROSSI S.P.A.	Postal address:	VIA GRUMOLO, N° 4
Azienda:		Indirizzo:	
Postcode and city:	36011 ARSIERO (VI)	Telephone number:	0445/741310
Codice postale e città:		Numero di telefono:	
E-mail address:	INFO@THERMOROSSI.IT		
Indirizzo e-mail:			

declare that the DoC is issued under our sole responsibility and belongs to the following product:
dichiara che la dichiarazione viene rilasciata sotto la propria responsabilità e si riferisce al seguente prodotto:

Apparatus model / Product:	Stufa a legna	Trademark:	THERMOROSSI
Descrizione prodotto:	Wood stove	Marchio:	
Models:	WAIR10		
Modelli:			

The object of the declaration described above is in conformity with the relevant Union harmonisation legislation:
L'oggetto della dichiarazione di cui sopra è conforme alla pertinente normativa di armonizzazione dell'Unione:

- **Direttiva 2014/30/UE, EMCD**
- **Direttiva 2014/35/UE, LVD**
- **Direttiva 2011/65/UE, RoHS**
- **2014/30/EU Directive, EMCD**
- **2014/35/EU Directive, LVD**
- **2011/65/EU Directive, RoHS**

Sono state applicate le seguenti norme armonizzate e/o specifiche tecniche:
The following harmonised standards and/or technical specifications have been applied:

EN 55014-1	EN 60335-1	EN 50581
EN 55014-2	EN 60335-2-102	Commission Regulation (EU) 2015/1185
EN 61000-3-2	EN 62233	
EN 61000-3-3		

Arsiero, 26/11/2025

Firma/Sign.



THERMOROSSI S.P.A.
Un amministratore

WAIR 10

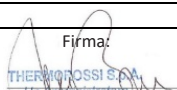
THERMOROSSI <i>The Experts</i>	DECLARATION OF PERFORMANCE IN ACCORDANCE WITH REGULATION (EU) 305/2011	n°A48
1 - Unique identification code of the product type:		WAIR10
2 - Model, batch, series (Article 11, paragraph 4):		WAIR10
3 - Intended uses of the construction product, in accordance with the relevant harmonised technical specification:		Domestic heating appliance, without water, fuelled by wood logs
4 - Registered name and address of the manufacturer (Art. 11, paragraph 5):		THERMOROSSI S.P.A. Via Grumolo, n° 4 36011 Arsiero (VI) Tel.0445/741310
5 - Name and address of the representative (Art. 12, paragraph 2):		-
6 - System for assessing and verifying the constancy of performance of the construction product referred to in Annex V:		System 3 and 4
7 - Notified laboratory:		Kiwa Italia S.p.a. N° 0476
Harmonised technical specification:		EN 16510-2-1
Test report number according to system 3:		0476-AoP-CPR-6014258
8 - Declared performance:		
	Essential features	Performance
Fire resistance		A1
Minimum safety distances from combustible materials in millimetres:		
Back / Side / Front / Ceiling / Floor		200 / 200 / 2000 / 750 / 100
Risk of fuel leakage:		Compliant
Surface temperature:		Compliant
Electrical safety:		Compliant
Accessibility and cleanliness:		Compliant
Emission of combustion products:		
at nominal power / at reduced power (mg/m3 at 13% O2):		353 / -
Maximum operating pressure:		N.A.
Flue gas temperature at nominal power:		186
Mechanical strength (to support the chimney/fuel):		Compliant
Nominal thermal power (kW)		10,1
Heat output to the environment (kW)		10,1
Heat output transferred to water (kW)		-
Energy efficiency at nominal heat output		88
Energy efficiency at reduced heat output		-
9 - Le prestazioni del prodotto di cui ai punti 1 e 2 sono conformi alla prestazione dichiarata di cui al punto 8		
Si rilascia la presente dichiarazione di prestazione sotto la responsabilità esclusiva del fabbricante di cui al punto 4.		
Arsiero, 26/11/2025		Firma:  THERMOROSSI S.P.A. Un Administrator

IT - SCHEDA PRODOTTO (UE 2015/1186) EN - PRODUCT FICHE (EU 2015/1186) FR - FICHE PRODUIT (UE 2015/1186) NL - PRODUCTGEGEVENSBLAD (EU 2015/1186) DE - PRODUKTDATENBLATT (EU 2015/1186) ES - FICHA DE PRODUCTO (UE 2015/1186)	IT - MARCHIO EN - BRAND FR - MARQUE NL - MERK DE - MARKE ES - MARCA	THERMOROSSI S.P.A.
IT - MODELLO EN - MODEL FR - MODÈLE NL - MODEL DE - MODELL ES - MODELO		WAIR10
IT - CLASSE DI EFFICIENZA ENERGETICA EN - ENERGY EFFICIENCY CLASS FR - CLASSE D'EFFICACITÉ ÉNERGÉTIQUE NL - ENERGIE EFFICIENTIEKLASSE DE - ENERGIEEFFIZIENZKLASSE ES - CLASE DE EFICIENCIA ENERGÉTICA		A+
IT - POTENZA TERMICA DIRETTA EN - DIRECT HEAT OUTPUT FR - PUISSANCE THERMIQUE DIRECTE NL - DIREKTE WARMTEAFGIFTE DE - DIREKTE WÄRMELEISTUNG ES - POTENCIA CALORÍFICA DIRECTA		10,1 kW
IT - POTENZA TERMICA INDIRETTA EN - INDIRECT HEAT OUTPUT FR - PUISSANCE THERMIQUE INDIRECTE NL - INDIRECTE WARMTEAFGIFTE DE - INDIRECTE WÄRMELEISTUNG ES - POTENCIA CALORÍFICA INDIRECTA		-
IT - INDICE DI EFFICIENZA ENERGETICA EN - ENERGY EFFICIENCY INDEX FR - INDICE D'EFFICACITÉ ÉNERGÉTIQUE NL - ENERGIE-EFFICIENTIE-INDEX DE - ENERGIEEFFIZIENZINDEX ES - ÍNDICE DE EFICIENCIA ENERGÉTICA		118
IT - EFFICIENZA UTILE ALLA POTENZA TERMICA NOMINALE EN - USEFUL ENERGY EFFICIENCY AT NOMINAL HEAT OUTPUT FR - RENDEMENT UTILE À LA PUISSANCE THERMIQUE NOMINALE NL - NUTTIG RENDEMENT BIJ NOMINAAL VERMOGEN DE - BRENNSTOFF-ENERGIEEFFIZIENZ BEI NENNWÄRMELEISTUNG ES - EFICIENCIA ENERGÉTICA ÚTIL A POTENCIA CALORÍFICA NOMINAL		88
IT - EFFICIENZA UTILE AL CARICO MINIMO EN - USEFUL ENERGY EFFICIENCY AT MINIMUM LOAD FR - RENDEMENT UTILE À LA CHARGE MINIMALE NL - NUTTIG RENDEMENT BIJ MINIMALE WARMTEAFGIFTE DE - BRENNSTOFF-ENERGIEEFFIZIENZ BEI MINDESTLAST ES - EFICIENCIA ENERGÉTICA ÚTIL A CARGA MINIMA		-
IT - RISPETTARE TUTTE LE ISTRUZIONI RIPORTATE SUL MANUALE DI INSTALLAZIONE USO E MANUTENZIONE EN - ALWAYS FOLLOW THE INSTRUCTIONS PROVIDED IN THE OPERATING AND MAINTENANCE MANUAL FR - RESPECTER TOUTES LES INSTRUCTIONS CITÉES DANS LA NOTICE D'INSTALLATION, UTILISATION ET ENTRETIEN NL - VOLG ALTIJD DE INSTRUCTIES VAN DE INSTALLATIE-, GERUIKERSHANDLEIDING EN DE ONDERHOUDSVOORSCHRIFTEN DE - ERFÜLLEN DIE ANWEISUNGEN DER INSTALLATION, NUTZUNG UND WARTUNG, DIE IN DER ANLEITUNGBUCH SIND ES - RESPECTAR LAS INSTRUCCIONES REPORTADAS EN EL MANUAL DE UTILIZACIÓN Y MANTENIMIENTO		

1 – INTRODUCTION

1.1 SAFETY GUIDELINES

This installation, use and maintenance manual is an integral and essential part of the product and must be kept by the user. Before commencing with the installation, use and maintenance of the product, carefully read this guide. All local, national and European regulations regarding the installation and use of the appliance must be met. The Manufacturer recommends carrying out all the maintenance operations described in this manual.

This appliance must only be used as intended by the manufacturer. Any other use is considered incorrect and therefore hazardous; consequently, the user shall be totally liable for the product if used improperly. Installation, maintenance and repairs must be carried out by professionally qualified personnel, certified according to Decree no. 37 of 22 January 2008 and in compliance with current regulations. In case of repairs only original spare parts supplied by the manufacturer must be used. Incorrect installation or poor maintenance can injure or damage people, animals or things; in this case the manufacturer shall be relieved of all responsibility. Any repairs or actions carried out on any systems, components or internal parts of the appliance, or on any of the accessories supplied with it, that are not specifically authorised by Thermorossi S.p.A, will automatically void the warranty and the manufacturer's responsibility, pursuant to Italian Decree no. 224 of the President of the Republic of 24/05/1988, art. 6/b. It is recommended to keep this manual in a safe place that is easily accessible to all users. If the manual is lost or deteriorated contact the manufacturer for a replacement copy. If the appliance is sold or transferred to another user ensure that the manual is handed over with it. The images and figures featured in this manual are purely illustrative and may differ from the actual product. Furthermore, Thermorossi reserves the right to apply changes to the content of this manual anytime and without notice.

Thermorossi S.p.A. retains copyright on this manual. These instructions may not be reproduced or communicated to third parties or used in any other way without the necessary authorisation.

1.2 SAFETY STANDARDS



PERSONAL INJURY

This safety symbol identifies important messages throughout the manual. Read the information marked by this symbol carefully as non-observance of this message can cause serious injury to persons using the appliance.



DAMAGE TO PROPERTY

This safety symbol identifies messages or instructions that are fundamental for the appliance and system to function well. To avoid serious damage to the appliance adhere strictly to these instructions.



INFORMATION

This symbol indicates important instructions for good functioning of the appliance. If this information is not correctly observed, the performance of the appliance will not be satisfactory.

1.3 RECOMMENDATIONS



Read this entire use and maintenance manual carefully before using the appliance as familiarity with the information and instructions contained in it are essential for the correct use of the appliance. No responsibility will be accepted for damages, even to third parties, if the instructions for installation, use and maintenance of the appliance are not followed scrupulously. Modifications made to the appliance by the user or on his behalf, must be considered to be under his complete responsibility. The user is responsible for all the operations required for the maintenance of the appliance before and during its use.



Should you notice an excessive stagnation of flue gas in the combustion chamber, move away from the appliance immediately. In particular move away from the glass door of the combustion chamber. The excessive concentration of unburned gases could create an explosion that could break the glass. Do not open the loading door for any reason whatsoever and do not approach the product until the flame has died down. Contact a technical service centre to determine the causes. Do not turn on the appliance for any reason whatsoever following an event such as this.

1.4 GENERAL GUIDELINES

The product must not be used by children under the age of 8 years, by persons with physical, mental or sensorial impairments, or by persons who are not familiar with the instructions for use and maintenance of the product (the instructions are found in this manual). Children must not play with the appliance.

ATTENTION: before lighting check that the grate of the combustion chamber is clean and that the ash pan is clean. **ATTENTION:** it is strictly forbidden to open the door while the flame is still burning. During operation, the smoke exhaust pipes, door, handles and some parts of the appliance may reach extremely high temperatures: be careful not to touch them and also educate children to be aware of said risks. Do not expose your body to hot air for long, do not overheat the room in which the appliance is installed, as these actions could cause health problems.

Do not expose plants or animals directly to the hot air flow as this could have noxious effects on them. Do not place non-heat resistant or inflammable or combustible objects in the vicinity of the appliance: keep them at a suitable distance. Do not place wet clothing to dry on the appliance. When using a clothes horse, keep at a suitable distance.



Attention: do not wet the appliance. Never vacuum hot ash: this could damage the vacuum device. All the cleaning operations described in this manual must be carried out when the appliance is cold.



Attention! Warning for Swiss users.

Refer to the local cantonal regulations imposed by the Fire Department (Mandatory signalling and safety distances) and the Note concerning installation of heaters issued by the Association of Cantonal Fire Agencies (VKF - AEAI).

1.5 TRANSPORTATION AND STORAGE

TRANSPORTATION AND HANDLING

The appliance body must always be handled exclusively by means of trolleys. Take special care to protect the glass and all the fragile parts from mechanical impact which could damage them and their correct functioning.

STORAGE

The appliance must be stored in a humid-free environment and sheltered from the weather; avoid placing the appliance directly on the ground. The Company denies all responsibility for damage caused to wood floors or floors made from any other material. It is inadvisable to store the product for long periods of time.

1.6 GUIDELINES FOR CORRECT DISPOSAL OF THE PRODUCT



At the end of the product's useful life, it must be disposed of in compliance with applicable regulations and in respect of the environment, not with urban waste. The product must be consigned to designated sorted waste collection centres for the disposal of waste authorised by the local municipal councils. Correct disposal not only helps safeguard the environment but it also promotes recovery and recycling of the materials.

WAIR 10

2 – TECHNICAL CHARACTERISTICS

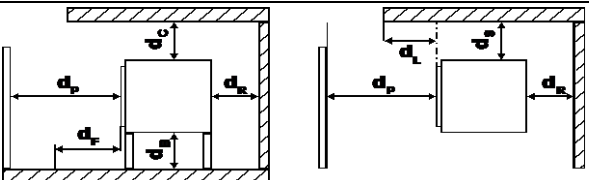
	PARAMETER	UNIT	WAIR10
Firebox Power**	Pfoc	kW	11,4
Nominal heat output**	Pnom	kW	10,1
Heat output to the environment **	PSHnom	kW	10,1
Water heat output**	PWnom	kW	-
Heat output at part load**	Part	kW	-
Heat output to the environment at partial load **	PSHpart	kW	-
Water heat output at partial load**	PWpart	kW	-
Efficiency at rated thermal output**	η_{nom}	%	88
Efficiency with thermal power at partial load**	η_{part}	%	-
Rated power consumption**	-	Kg/h	2,6
Reduced power consumption**	-	Kg/h	-
Tank capacity	-	Kg	16
Seasonal efficiency at nominal power	η_S	%	78
Energy efficiency index	EEl	-	118
CO emissions with 13% O2 at rated power**	CONom (13%O ₂)	mg/m ³	353
CO emissions with 13% O2 at partial load**	COpart (13%O ₂)	mg/m ³	-
NOx emissions with 13% O2 at rated power**	NOXnom (13%O ₂)	mg/m ³	95
NOx emissions with 13% O2 at partial load**	NOXpart (13%O ₂)	mg/m ³	-
OGC emissions with 13% O2 at rated power**	OGCnom (13%O ₂)	mg/m ³	28
OGC emissions with 13% O2 at partial load**	OGCpart (13%O ₂)	mg/m ³	-
Particulate emissions with 13% O2 at rated power**	PMnom (13%O ₂)	mg/m ³	15
Particulate emissions with 13% O2 at partial load**	PMpart (13%O ₂)	mg/m ³	-
Minimum chimney draught at rated power	pnom	Pa	12
Minimum chimney draught at partial load	ppart	Pa	12
Maximum permissible working pressure of water	pW	bar	-
Water content of the appliance		l	-
Minimum safety distances from combustible materials:	dR	mm	200
	dS	mm	200
	dC	mm	750
	dP	mm	2000
	dF	mm	1500
	dL	mm	1500
	dB	mm	100
Minimum distances from non-combustible walls:	dnon	mm	50
Electricity consumption in standby mode	eISB	kW	-
Electricity consumption at rated power	elmax	kW	-
Electricity Consumption at partial load	elmin	kW	-
Supply voltage, frequency	E, f	V, Hz	-
Maximum electrical power consumption	Vmax	W	-
Exhaust gas temperature at rated power**	Tsnom	°C	186
Partial load exhaust gas outlet temperature**	Tspart	°C	-
Chimney designation	Tclass	-	T400G
Exhaust gas flow at rated power**	$\varphi_{f,g nom}$	g/s	7
Exhaust gas flow at partial load**	$\varphi_{f,g part}$	g/s	-
Continuous operation (CON) or intermittent operation (INT)	CON o INT	-	INT
Exhaust gas outlet diameter	dout	mm	150
Type of appliance	TYPE	-	TYPE BE
Air tightness loss	Vh	m ³ /h	-
Length, height, width	L, H, W	mm	600, 1079, 463
Unloaded weight	m	Kg	142
Maximum weight that the chimney can bear	mchin	Kg	0
Heatable volume*		m ³	273

** All the data were measured using billets of wood with 12% moisture content and thermal value of 15,604 KJ/Kg.

* Important: take into consideration the fact that the heatable volume is greatly influenced by the insulation of the house, i.e., the energy class of the building and by the position of the appliance in the planimetry of the house. The indicated values, therefore, can vary considerably. The data refer to an absorption coefficient of 37 W/m³.

*** It is strictly prohibited to load a greater quantity of fuel than that specified in the table. The warranty will not cover damages caused by the prolonged exposure of the appliance to temperatures that are too high.

WAIR 10

2.1 DIMENSIONS

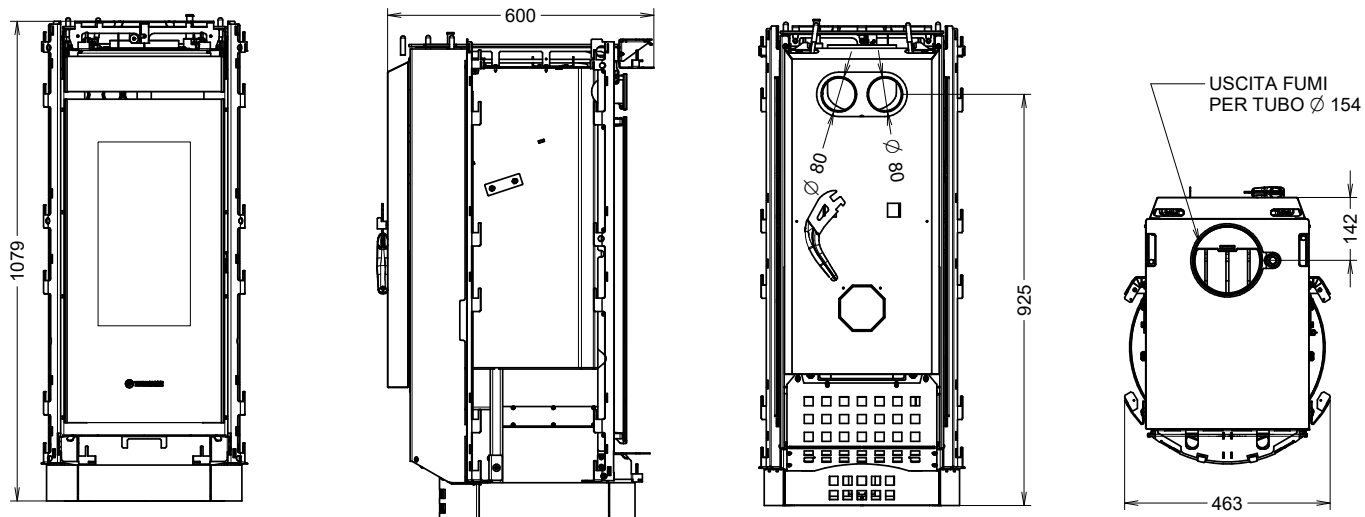

The appliance's smoke outlet collar is female. So, to mount the exhaust pipe, it is necessary to firstly fit a heavy steel male tube with 2mm thick walls to it.

Legenda	Key
USCITA FUMI PER TUBO Ø 154	SMOKE OUTLET FOR TUBE Ø 154

WAIR 10

3 – GENERAL DESCRIPTION

3.1 THE FUEL

The fuel for this appliance is ordinary wood billets with a moisture content between 10% and 20% and with a thermal value of 10,400 to 16,400 KJ/kg. We recommend using beech or common hornbeam.

If using wood with a lower moisture content or with a higher thermal value the heat produced by the stove will be greater. The awareness and use of the right fuel are important aspects to be observed in order to ensure correct operation and long service life of the appliance.

To this end we recommend using only dry, well-seasoned wood. We recommend against using wet wood or wood that has been seasoned for less than 18/20 months, as this could be the cause of malfunctions and the formation of tarry deposits that could permanently blacken the walls of the combustion chamber.

We recommend the use of 250 mm long wood billets; load a maximum of 2-3 billets at the time and in any case do not exceed the maximum weight stated in the technical data. The fuel feed intervals must not be less than those specified in the technical data table.



LOADING A LARGER QUANTITY OF FUEL OR LOADING SEVERAL TIMES IN AN HOUR EXPOSES THE COMPONENTS OF THE APPLIANCE TO VERY HIGH TEMPERATURES. FOR THIS REASON, THE WARRANTY WILL NOT COVER ANY DAMAGE CAUSED BY PROLONGED EXPOSURE OF THE APPLIANCE TO THESE TEMPERATURES.



The use of fuel that does not comply with the above specifications or the use of different substances or fuels will immediately void the appliance warranty. The appliance must not be used as an incinerator, and it is prohibited to use any liquid or gas fuel. Do not overload the stove with excessive quantities of fuel; adhere strictly to the maximum declared consumption.

3.2 MAIN COMPONENTS



Figura 1



Figura 2

KEY

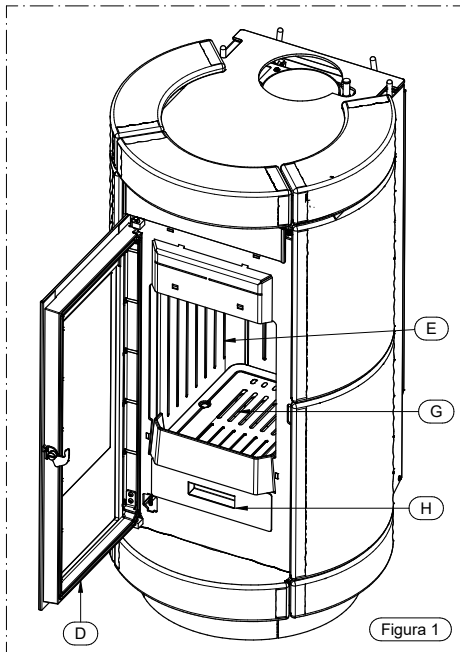
- A Primary air lever
- B Secondary air lever
- C Smoke Bypass device
- D Door firebox
- E Combustion chamber
- G Combustion chamber grate
- H Ash pan
- L RH channelling lever
- M LH channelling lever

A – Primary air lever

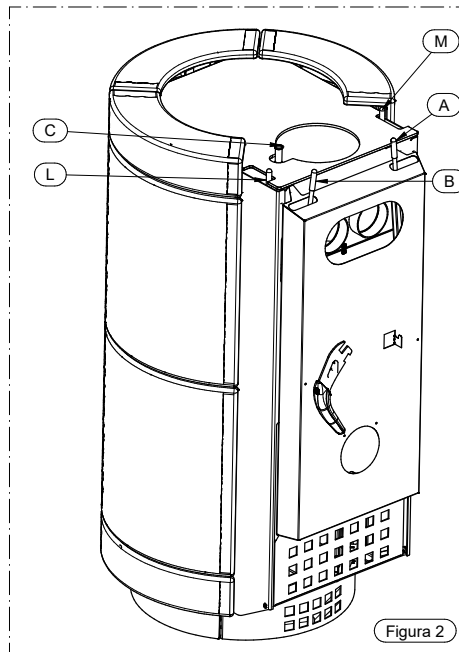
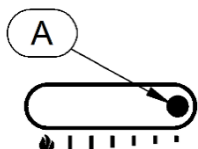

It is used to regulate the primary air inflow. The primary air passes through the grate of the combustion chamber and feeds the combustion and determines the combustion power and speed.

Regulation of the air is facilitated by 6 bars printed on the upper glass. To decrease the air inflow, shift the lever in the direction of the smallest bar. Whereas to increase the inflow air shift it in the direction of the bigger bars.



ATTENTION: when the appliance is operating the temperature of the primary air lever is very high, so take care not to touch it. Use only the handle provided to move the lever.

B – Secondary air lever

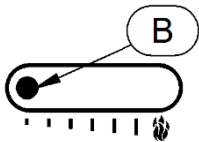

It is used to regulate the secondary air inflow. As the secondary air passes through the holes in the back wall of the combustion chamber, it preheats and contributes to the second combustion as well as having the function of keeping the glass clean.

Regulation of the air is facilitated by 6 bars printed on the upper glass. To decrease the air inflow, shift the lever in the direction of the smallest bar. Whereas to increase the inflow air shift it in the direction of the bigger bars.



ATTENTION: when the appliance is operating the temperature of the secondary air lever is very high, so take care not to touch it. Use only the handle provided to move the lever.

C –Smoke Bypass Device

This device creates a direct bypass for the flue gases which facilitates both the lighting and refuelling operations. It must only be activated with the special handle supplied and only when lighting or refuelling the wood; take care not to damage the majolica tiles or the upper glass.



IT IS STRICTLY PROHIBITED TO LEAVE THE SMOKE BYPASS DEVICE OPEN DURING NORMAL OPERATION. Leaving the Smoke Bypass open during normal operation results in higher fuel consumption than the declared quantity, a considerable drop in efficiency and exposure of the appliance to extremely high temperatures. For this reason, the warranty will not cover any damage caused by prolonged exposure of the appliance to these temperatures.



ATTENTION: the temperature of the Smoke Bypass device during operation is very high so take care not to touch it. Use only the handle provided to move the lever.

Pulling the Smoke Bypass Device upwards activates the direct bypass of the flue gases, whereas pushing the Smoke Bypass Device downwards activates the normal flue gas path.

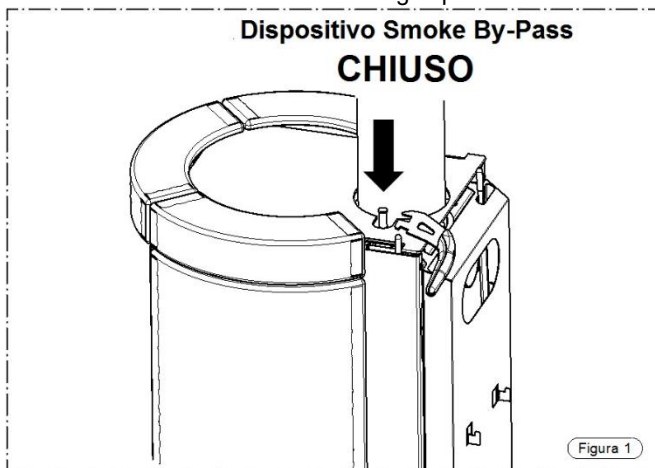

D – Firebox door

When the appliance is operating the door must remain firmly closed and airtight. It must only be opened to refuel.

E – Combustion chamber

The combustion chamber is made of cast iron. We recommend you do not throw the firewood into the combustion chamber as it could crack. The presence of cracks does not affect the correct operation of the appliance. Replacement is not covered by the product warranty.

G –Combustion chamber grate

H – Ash pan

Collects the ash produced by combustion. It must be emptied regularly.

L – RH channelling lever

This lever is used to regulate the hot air inflow from the front or back. If the appliance is fitted with Airbox 1 (optional) it enables regulation of the flow from the right rear channelling.

M – LH channelling lever

This lever is used to regulate the hot air inflow from the front or back. If the appliance is fitted with Airbox 1 (optional) it enables regulation of the flow from the left rear channelling.

Legenda	Key
Dispositivo Smoke By-Pass	Smoke Bypass Device
APERTO	OPEN
CHIUSO	CLOSED
Figura	Figure

WAIR 10

4 – INSTALLATION

4.1 APPLIANCE LOCATION



Follow the general guidelines set out in paragraph 1.1 to the letter. Above all keep in mind that the floor of the installation site must be capable of bearing the weight of the appliance added to the weight of the casing. If this requirement is not met, it is obligatory to adopt counter measures (for example, load distribution plate ...)



ATTENTION: the room where the appliance is installed must be well ventilated and free from humidity and salty air. A high level of humidity or saltiness in the room can lead to the onset of rust or corrosion which will not be covered by warranty. The appliance must be positioned at a minimum safe distance from walls and furnishings. If inflammable materials are located in the vicinity of the appliance (e.g.: matchboarding, furniture, curtains, pictures and paintings, sofas) the minimum distances indicated in the technical specifications table must be observed.



If the flooring is made of wood or any other combustible material, it is recommended to install a fireproof floor protector plate between the appliance and the floor. Installation in the vicinity of heat-sensitive materials is only permitted if suitable insulating and fireproof protection is placed between the object and the appliance (ref. Uni 10683). Failure to observe this instruction will immediately invalidate the warranty.

The installer must issue a certificate of conformity for the installation which includes the design plans and the following documents:

- a) Report containing the type of materials utilised.
- b) Project as defined in Article 5 of Ministerial Decree n° 37 22 January 2008.
- d) References to existing partial or previous declarations of conformity (e.g. flue outlet).
- e) Copy of the certificate of recognition of the professional technical qualifications.



These documents must, by law, be kept together with the use and maintenance booklet. The customer is responsible for verifying, directly or indirectly, that the installation has been carried out to perfection in accordance with relevant regulations in force. Do not install the appliance in unsuitable rooms such as bedrooms, bathrooms, garages and/or lock-ups. It is forbidden to place the appliance in environments with an explosive atmosphere.



ATTENTION, the appliance is not simply a household appliance: if the instructions set out in this booklet are not followed and/or if installation of the appliance is not executed perfectly and/or the provisions in force are not strictly complied with, dangerous conditions could arise for both objects and persons. It is the user's responsibility to verify the presence, in the room, of a vent necessary for supplying oxygen to the appliance.

4.2 UNPACKING THE APPLIANCE

The appliance is supplied packaged on a pallet; before positioning and installing it dismantle the appliance from the pallet as described.

- Remove the cover and the side panels of the pallet (A) and also the protection panel (B) (Figure 1).
- Use a screwdriver to undo the 2 screws (C) (see Figures 2 and 3).
- Remove the protection panel (D) from the combustion chamber (see Figure 4).

ATTENTION IMPORTANT: HANDLE THE BOILER WITH CARE AS DAMAGE CAUSED DURING THE UNPACKING OPERATION WILL NOT BE COVERED BY THE WARRANTY.



Figura 1



Figura 2

Figura 3

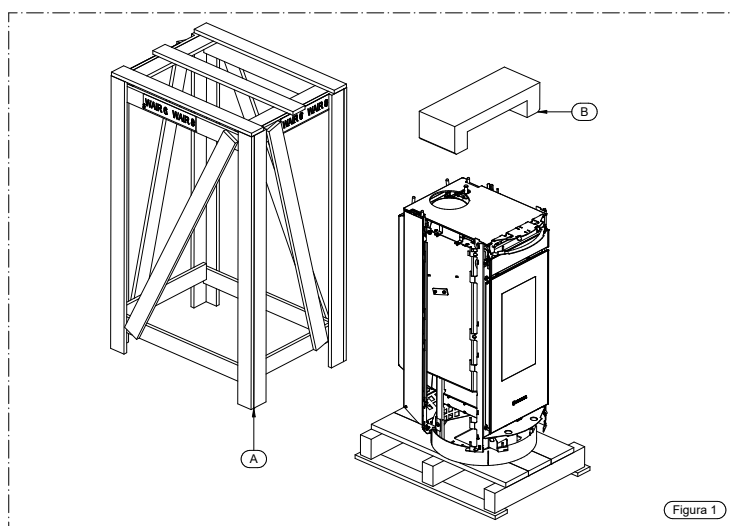
Figura 4

4.3 UNPACKING/MOUNTING THE CASING

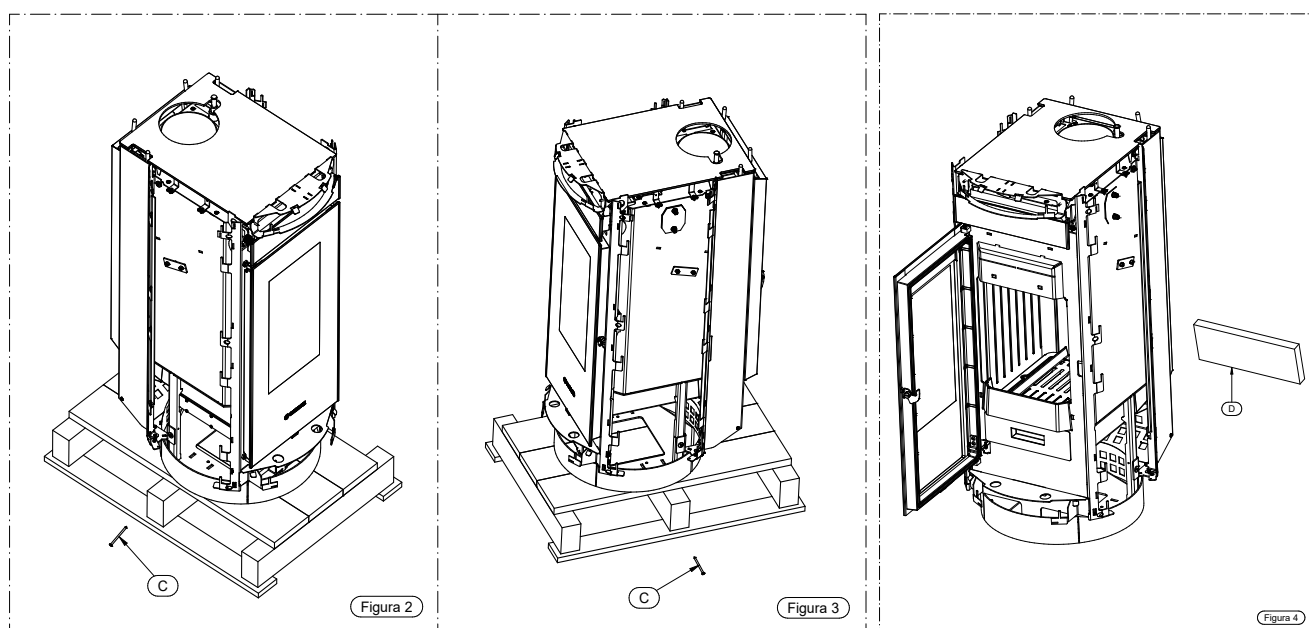
See the specific manual for the dedicated casing.

4.4 CONNECTING THE APPLIANCE TO THE FLUE OUTLET

Connection of the appliance to the flue outlet must be carried out in strict compliance with the instructions contained in this booklet and particularly with those in the dedicated chapter.

WAIR 10

4.5 DRAWING COMBUSTION AIR FROM OUTSIDE

It is possible to draw combustion air directly from outside the building. In this case it is necessary to remove the back (A) by unscrewing the four screws (B) and install the appropriate flange (C) supplied in the accessories bag with screws (D) (Figures 1 and 2). Connect the air intake on the appliance to the exterior of the building with suitable piping. The maximum length of the piping is 60 cm.

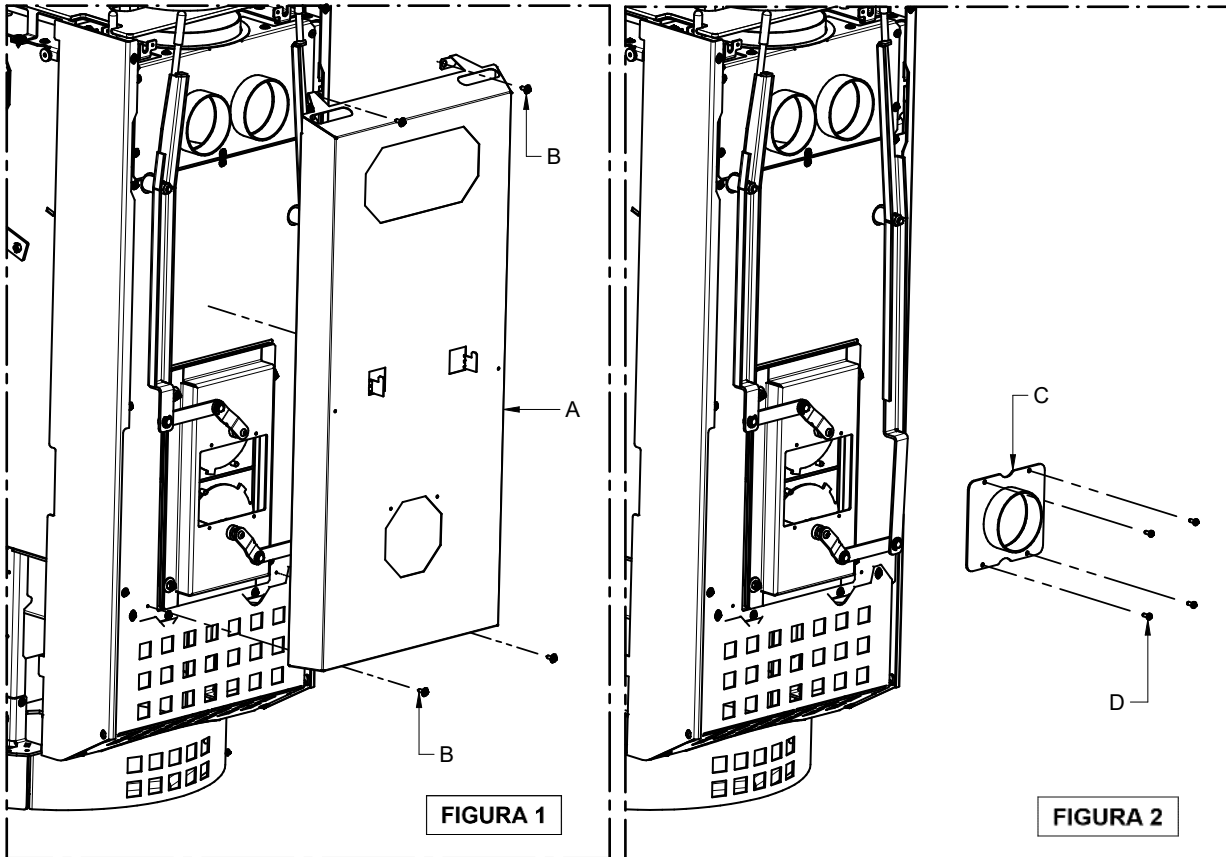

4.6 HANDLE

Your appliance is supplied with a handle for opening and closing the firebox door (Figure 2) to enable you to refuel the wood and to carry out cleaning operations (see dedicated paragraph). When not in use, the handle can be stowed on the rear of the appliance as indicated in Figure 1. Moreover, the handle will serve to regulate the primary air and the secondary air, to open and close the Smoke Bypass Device.

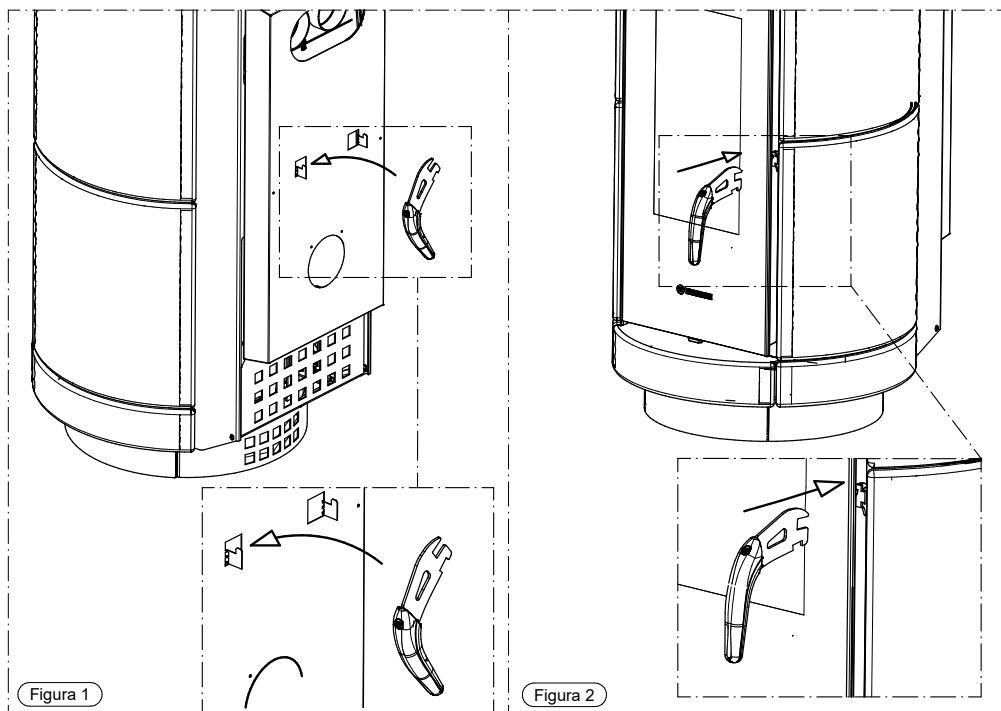

5 – USE OF THE APPLIANCE

The appliance, when operating, is hot to the touch, particularly the door of the combustion chamber: consequently, take care not to touch any surface. Your appliance has obtained the CE marking. The product must not be used by children, by persons with physical or mental impairments, by persons who are not familiar with the instructions for use and maintenance of the product (the instructions are found in this installation, use and maintenance manual). During the heating and cooling stages, the appliance is exposed to considerable thermal expansions that can cause light expansion sounds. This is a normal process and is not a defect of the product.



ATTENTION: the door must always remain shut tight when the appliance is operating. While the appliance is in operation, the smoke exhaust pipes can reach extremely high temperatures: do not touch them! It is strictly forbidden to use any type of liquid or gaseous fuel to light the appliance. Do not place non-heat resistant or inflammable or combustible objects in the vicinity of the appliance: keep them at a suitable distance. Do not place wet clothing to dry on the appliance. When using a clothes horse, keep at a suitable distance. During the first lighting it is quite normal for the paint on the product to give off a slight smell as it completes its drying process. It is recommended to ventilate the room until the paint has completely dried.

5.1 LIGHTING

Before using the appliance check that all the movable parts are correctly fitted. Also remove any labels and stickers from the glass to avoid that permanent traces remain on the surfaces. Also, check that the connection to the flue outlet has been made correctly.

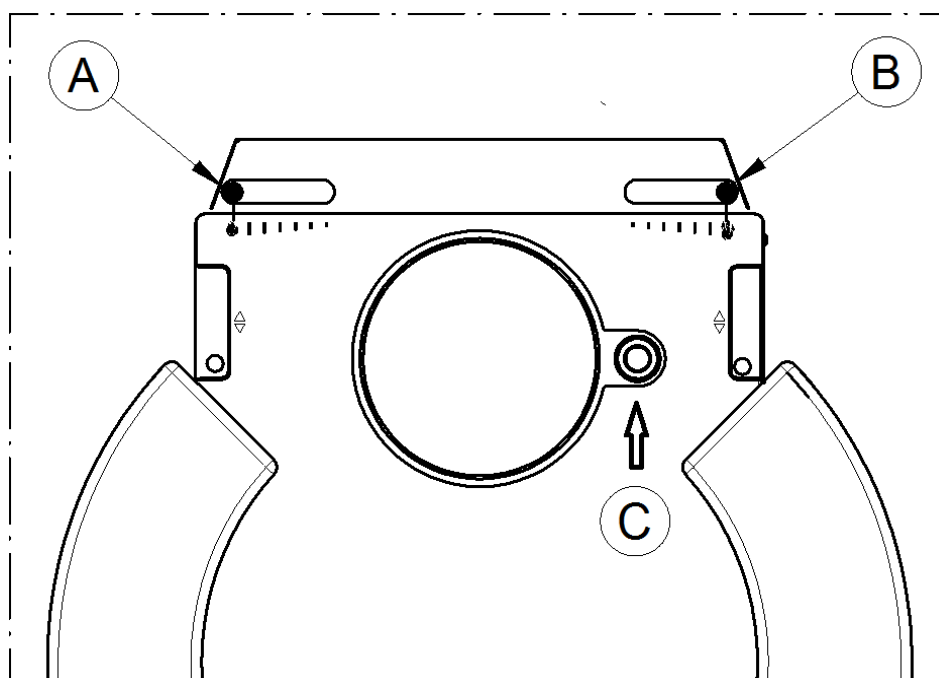

To startup the stove proceed as follows:

- 1) Open the Smoke Bypass Device (C) by pulling it up with the special handle provided.
- 2) Open the primary air (A) and the secondary air (B) completely by pushing the two levers outwards (see figure above).
- 3) Open the firebox door (D) with the special handle, place some kindling in the firebox and light it with paper or any other tinder available on the market, then close the firebox door (D).



IT IS PROHIBITED TO USE ANY LIQUIDS OR GASES SUCH AS ALCOHOL, PETROL, ETC., TO LIGHT OR REKINDLE THE FIRE.

- 4) Do not leave the appliance unsupervised while the lighting process is still in progress (roughly 30 minutes to complete the process) or whenever there are abundant burning embers present.
- 5) Once the lighting process is completed close the Smoke Bypass Device (C) using the special handle by pushing downward.

WAIR 10

5.2 REFUELLING

The stove is an intermittent combustion appliance so it requires refuelling. Once combustion is achieved inside the combustion chamber and consequently there are embers present, proceed with the first fuel feed:

- 1) Open the Smoke Bypass Device (C) by pulling it upwards with the special handle.
- 2) Wait a few seconds then slowly open the firebox door to avoid smoke outpour and spread out the embers using the supplied poker, as shown in Figure 1.

N.B. It is very important to ensure that the initial level of embers is approximately two centimetres. It is prohibited to light and reload the fuel with the embers at a higher or lower level as this will not guarantee correct use of the appliance.

- 3) Lay two billets of wood that do not exceed the weight specified in the technical data table, in a parallel position in the centre of the grate, approx 8-10 cm from the back of the combustion chamber (see Figure 2).

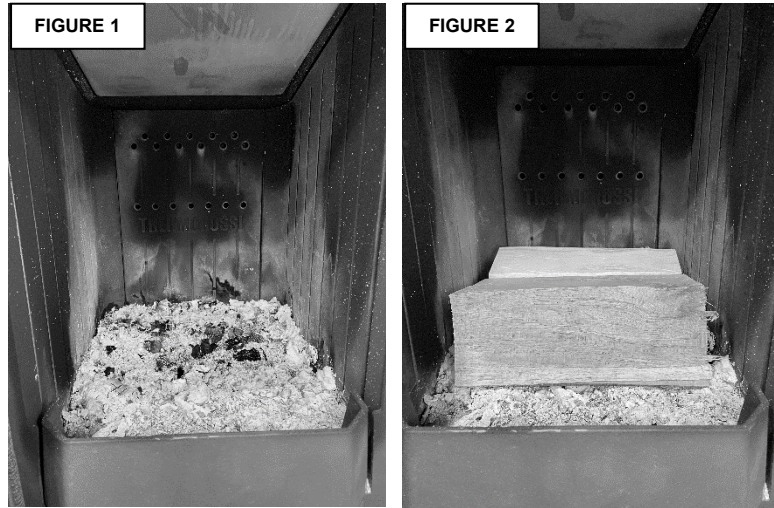

- 4) Slowly close the firebox door airtight using the special handle, close the Smoke Bypass Device (C) using the special handle by pushing it downwards.
- 5) It is recommended to regulate the primary air (A) and the secondary air (B) as follows:

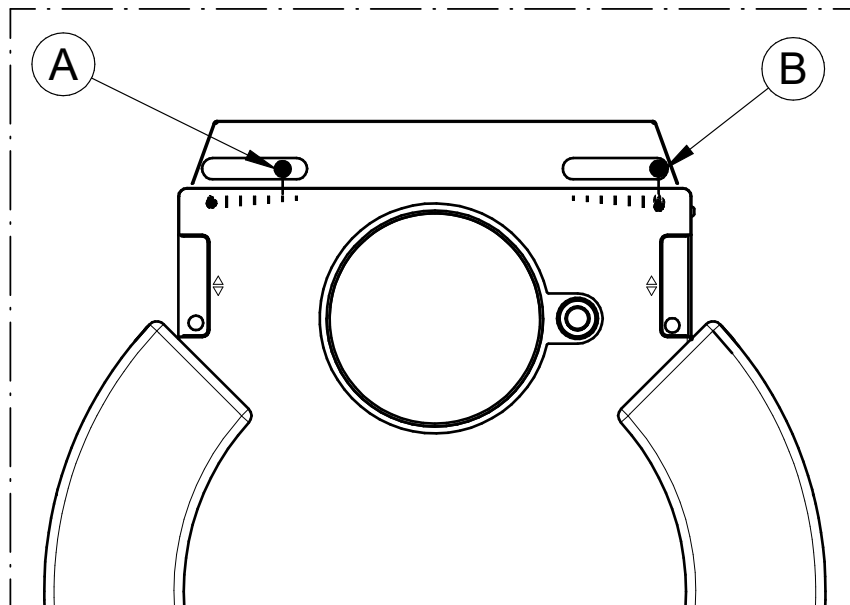

	WAIR10
Primary air lever	Open 2 bars
Secondary air lever	Totally opened

5.3 CHANNELLING

In the models fitted with Airbox1 (Optional) it is possible to convey the hot air flow to the front or to the channelling pipes at the rear. It is also possible to choose to distribute the flow partly to the front and partly to the channelling pipes at the rear.



ATTENTION: if one or both of the channelling collars are not used to channel the air it is mandatory to check the back of the appliance to make sure that there are no objects and /or materials that could be damaged by the heat.

To regulate the air flow, shift the left or right channelling levers.



ATTENTION: the temperature of the left and right channelling levers is very hot while the stove is operating, so take care not to touch them. Use only the handle provided to activate them.

L – RH channelling lever

Regulates the flow from the right side of the appliance and the setting options are as follows:

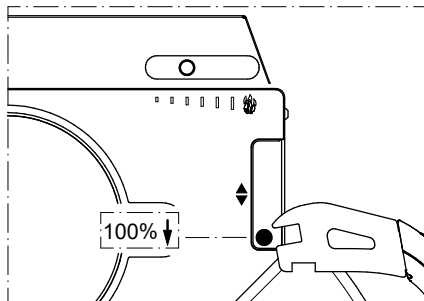
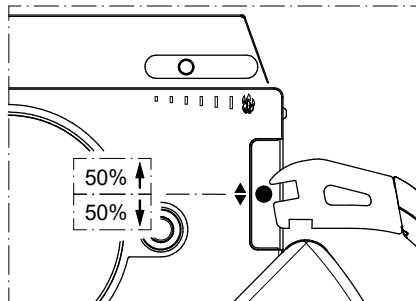
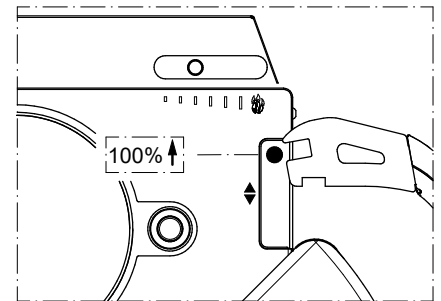
**100% Front****50% Front 50% Rear****100% Rear****M – LH channelling lever**

Regulates the flow from the left side of the appliance and the setting options are as follows:

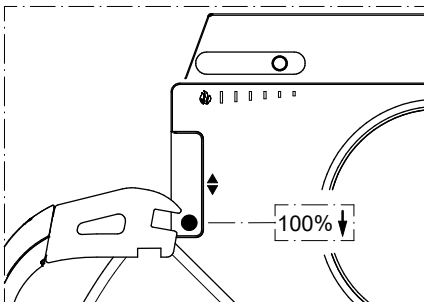
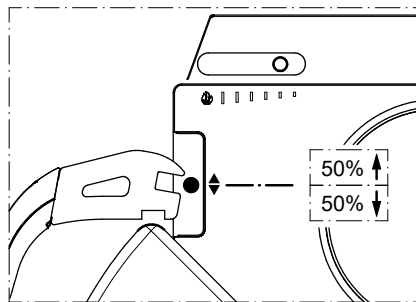
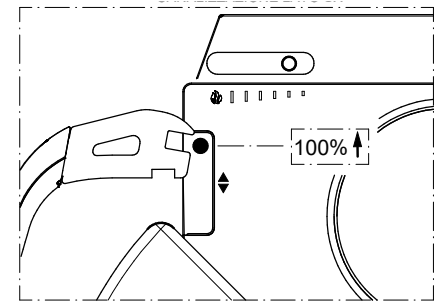
**100% Front****50% Front 50% Rear****100% Rear**

Prescriptions for correct channelling:

- It is prohibited to use plastic or internally corrugated pipes.
- It is prohibited to position sections with a downward slope.
- Reduce the number of bends as much as possible (maximum 4).
- To ensure a good result it is obligatory to insulate the pipes.
- Maintain a distance of at least 20 cm between the channelling pipes and any inflammable materials.
- It is prohibited to reduce any pipe sections, even partially, with respect to the outlet diameter.
- It is prohibited to install devices that could simultaneously close the channelling pipes.

WAIR 10

5.4 PRESCRIPTIONS FOR CORRECT OPERATION

- Respect the maximum declared consumption, do not overload the stove with excessive quantities of fuel as this could cause damage.



LOADING A LARGER QUANTITY OF FUEL OR LOADING SEVERAL TIMES IN AN HOUR EXPOSES THE COMPONENTS OF THE APPLIANCE TO VERY HIGH TEMPERATURES. FOR THIS REASON, THE WARRANTY WILL NOT COVER ANY DAMAGE CAUSED BY PROLONGED EXPOSURE OF THE APPLIANCE TO THESE TEMPERATURES.



DO NOT THROW THE WOOD INTO THE COMBUSTION CHAMBER, PLACE IT IN GENTLY. THROWING THE WOOD COULD END UP BREAKING PARTS. DAMAGE CAUSED IN THIS WAY IS NOT COVERED BY WARRANTY.

- The appliance must not be used as an incinerator, the use of liquid or gaseous fuels is prohibited.
- Adhere strictly to the operating instructions set out in this manual.
- Always verify that the fuel loaded into the combustion chamber lights correctly. Make sure that this always occurs to avoid any buildup of combustible gases. The buildup of a high quantity of combustible gases could exceed the mechanical resistance of the glass and other components of the stove. For this reason, the manufacturer disclaims all responsibility.
- In adverse weather conditions, such as for example low pressure, windy or rainy days or days with high outside temperatures, the effect could be a drop in draught or reverse draught. In these situations, the flue gases may not be completely exhausted. Consequently, in these cases it is necessary to increase the primary air and load the smallest amount of fuel in order to reactivate the draught of the flue outlet. If you notice the smell of smoke in the room or stagnation of gases inside the combustion chamber avoid using the appliance.
- The manufacturer recommends using 250 mm long firewood billets, and loading a maximum of 2-3 billets at a time, and in any case do not exceed the weight declared in the technical data.

6 – CLEANING AND MAINTENANCE

6.1 FOREWORD



To guarantee correct operation and optimal performance of the appliance at all times carry out the operations described below. Observe the recommended frequency.

If the product is unused for a prolonged period of time before starting up, it is mandatory to inspect the smoke channel and outlet to ensure that there are no obstructions. It is important to carefully follow the instructions set out below: failure to observe these instructions could cause serious damage to the product, to the system, to objects and to persons using the appliance.



Attention: do not wet or touch the appliance with wet hands. Never vacuum hot ash: this could damage the vacuum device. All the cleaning operations described in this manual must be carried out when the appliance is cold.



To clean the glass simply use a damp soft, non-abrasive cloth and ash. The use of any other product is strictly prohibited. Damage to the glass or the print will not be covered by warranty. Do not clean the glass until it has cooled completely.

The user must periodically clean the appliance, or have an authorised service centre clean it, as described in this manual. Moreover, once a year it is advisable to have an inspection carried out of the functionality of the flue outlet.

6.2 CLEANING AND MAINTENANCE

Figure 1



Figure 2



Figure 3

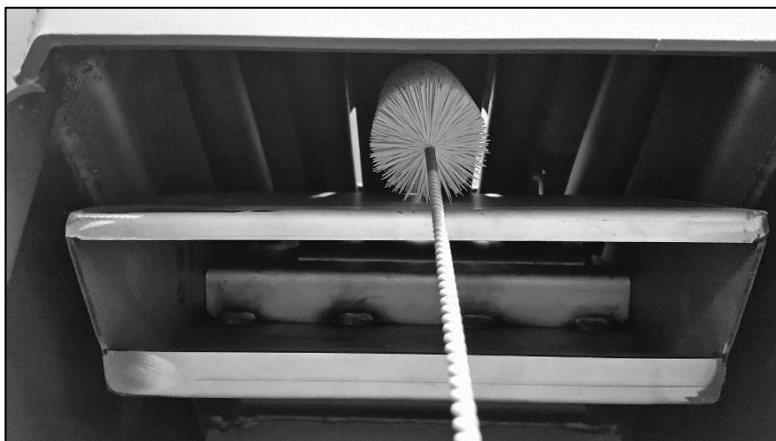

Figure 4

**EVERY DAY:**

- Thoroughly clean the grate of the combustion chamber (Figure 1) by making the ash drop through the holes in the grate;

EVERY TWO DAYS or WHENEVER NECESSARY:

- Empty the ash pan (Figure 2).

EVERY WEEK:

- Clean the exchanger of the smoke bypass with a vacuum device (Figure 3).

EVERY MONTH:

- Clean the gas tubes behind the smoke bypass with a special brush (Figure 4).

AT LEAST TWICE A YEAR:

- Clean the flue outlet. If there are any horizontal sections, inspect them and clean out any ash and soot deposits before they block the passage of the flue gases.

AT THE END OF THE WINTER SEASON (or whenever necessary)

- Perform a thorough overall cleaning of the firebox and pans with brushes and vacuum cleaners.



A vacuum device simplifies the ash cleaning procedure. The front and side casings must be cleaned when the heater is cold using a soft cloth and water. The door of the combustion chamber must only be opened when the appliance has completely cooled down: when it is opened it is normal for some ash to spill onto the floor.



WAIR 10

ATTENTION: after cleaning it is mandatory to carefully check that the combustion chamber door is firmly closed and airtight.

ATTENTION: the generator, the smoke channel and flue outlet must be cleaned in accordance with the specifications described above and use of inflammable products is strictly forbidden: using inflammable products can create dangerous situations. Failure to carry out the necessary maintenance or if only partial maintenance is carried out will affect the correct functioning of the appliance. Any problems resulting from total or partial lack of cleaning or maintenance will immediately void the warranty.



ATTENTION: if the appliance remains inactive (and/or not used for over a month) the generator, the smoke discharge tube and the flue outlet must be thoroughly cleaned and checked for any possible obstructions (e.g., birds nests in the chimney cap) before restarting.

7 – SMOKE DISCHARGE TUBE AND VENTILATION OF THE ROOMS

7.1 FOREWORD



Due to the frequent accidents caused by poor functioning of flue outlets installed in private dwellings, we have prepared the following paragraph to assist the installer in his inspection of the parts concerned with eliminating the gases produced by combustion.



The smoke outlet must be fitted in compliance with standard UNI 7129/92 and UNI 10683 and it must observe the reference values laid down in the standard, in particular, the outlet must comply with fire prevention regulations.

It is important to carefully follow the instructions set out below: failure to observe these instructions could cause serious damage to the product, to the system, to objects and to persons using the appliance.

7.2 ROOM VENTILATION



ATTENTION: the presence of extraction fans or similar appliances, if operating in the same room or space in which the product is installed, could cause problems for the correct operation of the product.

ATTENTION: do not obstruct the vents or the air inlets on the appliance.

The room where the appliance is installed must have a good air flow to guarantee air for the appliance for the combustion process and for ventilation of the room. The natural air flow must take place directly through permanent openings on the outer walls or through single or multiple ventilation ducting.

The ventilation air intake must be located away from pollution sources.

The openings in the walls must comply with the following conditions:

- have an unobstructed section of at least 6cm² for each Kw of installed thermal power, with a minimum limit of 100cm²;
 - be made in such a way that the vent openings, both on the inside and outside of the wall, cannot be obstructed;
 - be protected with grills or similar systems that do not reduce the opening section indicated above;
 - be situated at a height near-floor level and they must not obstruct the correct operation of the combustion product discharge devices;
- if this position is not possible, the section of the ventilation openings must be enlarged by at least 50%.

7.3 SMOKE OUTLET



The smoke channel, the exhaust pipe, chimney and flue outlet (defined as the system for the evacuation of combustion products), are parts of the heating system and they must comply with the legislative requirements of the Ministerial Decree DM 37/08 (ex Italian Law 46/90) and to the applicable specific installation regulations, according to the type of fuel. Fireplaces, stoves and barbecues must not be installed in locations where gas appliances type A and type B are present and operating (for the classification see UNI 10642 and UNI 7129). The connection between the appliance and the flue outlet must only receive exhaust from one heat generator.



The installer must provide one or more access points on the flue outlet to check the emissions once the appliance has been installed; these access points must be made in such a way as to be airtight sealable to prevent exhaust gas leaks. It is recommended to provide insulation and to ensure the optimal sizing of the flue outlet in order to avoid the possible risk of condensation forming in the flue outlet.

7.3.1 CHIMNEY TYPES

The following types of chimneys, constructed as described, are possible:

- System: Chimney installed using a combination of compatible components (flue liner, insulation, outer casing etc...), constructed or specified by a single manufacturer and CE certified in accordance with the applicable standard;
- Composite chimney: Chimney installed or constructed on site using a combination of compatible components such as flue liner (wall directly in contact with the smoke), and possibly also insulation and outer casing (wall) that may be supplied by different manufacturers or by the same manufacturer;
- Relining: operation involving the installation of a specific pipe in an existing shaft (even if newly constructed) made of non-combustible materials, free from obstructions and for single use.

WAIR 10

7.3.2 FLUE OUTLET / FLUE SYSTEM COMPONENTS

Every chimney must have minimum number of components as laid down by standard UNI EN 1443 which are also indicated in the figure below:



ATTENTION: wall outlets, that is outlets installed on the outer front wall without the use of a chimney/flue outlet /flue pipe to convey the combustion products to the roof, are strictly prohibited.

7.3.3 CONTROLS PRIOR TO INSTALLING THE APPLIANCE

The user must possess a certificate of conformance for the flue outlet (Ministerial Decree 22 January 2008, no. 37).

The flue outlet must be built in compliance with UNI 10683.

The smoke exhaust illustrated in the following figure is the best solution required to ensure that the flue gases are discharged. If you prefer to exhaust the smoke from the roof insert a union tee with inspection cap, connecting brackets suitable for the height of the flue outlet, flashing that crosses the roof and chimney cap to protect against bad weather conditions.

If you decide to use the classic masonry exhaust provide a union tee with inspection cap and suitable supporting brackets. If the flue outlet is too big, it is necessary to insert a stainless steel or porcelain-coated steel tube with suitable diameter.

Seal area where the inlet and outlet part of the smoke exhaust meets the wall. It is strictly forbidden to apply mesh to the end of the outlet tube, as it could cause the appliance to malfunction.

If the smoke tube is installed in a fixed position, it is advisable to provide inspection openings for clean-out purposes especially in the horizontal sections. See the diagram. These openings are essential allow for the removal of ash and unburned products which tend to accumulate along the discharge path. Seal the fittings with red silicone (resistant to 350°C).

The outer casing of the tube must be made with insulating material (mineral wool, ceramic fibre) or use pre-insulated tubing.

THE FLUE OUTLET MUST BE USED ONLY FOR THE APPLIANCE.

It must be possible to inspect and remove all the smoke tube sections for clean-out purposes.



ATTENTION: if the flue outlet is not sufficiently insulated and /or if it is too long it could generate condensation. It is advisable to provide a condensation drain near the smoke outlet of the appliance. The appliance must always and only be installed in a single flue outlet system dedicated exclusively to the appliance. If the generator is connected to a non-compliant flue system the appliance could rapidly deteriorate due to an abnormal, continuous overheating: in this case the damaged parts will not be covered by warranty.

Components and accessories of a chimney

Key

- 1 Chimney
- 2 Flow path
- 3 Smoke discharge tube
- 4 Thermal insulation
- 5 External wall
- 6 Outer lining
- 7 Flue outlet section
- 8 Multiwall chimney
- 9 Connector
- 10 Flue pipe
- 11 Heat generator

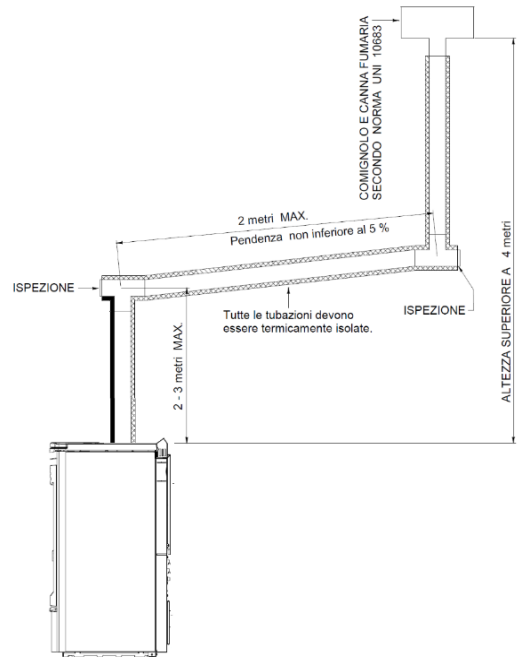
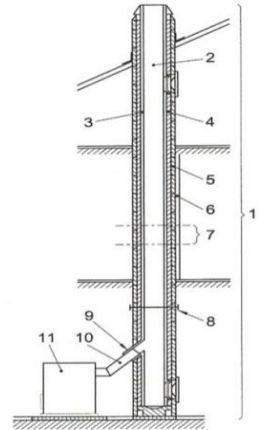

LEGENDA	KEY
COMIGNOLO E CANNA FUMARIA SECONDO NORMA UNI 10683	CHIMNEY CAP AND FLUE OUTLET ACCORDING TO UNI 10683 STANDARD
Tutte le tubazioni devono essere termicamente isolate	All the pipes must be thermally insulated
ISPEZIONE	INSPECTION
2 metri MAX	2 metres MAX
2 -3 metri MAX	2 -3 metres MAX.
Pendenza non inferiore al 5%	Minimum slope 5%
ALTEZZA SUPERIORE A 4 m	HEIGHT MORE THAN 4 m.

IF THE CHIMNEY CATCHES FIRE CLOSE THE PRIMARY AND SECONDARY AIR LEVERS IMMEDIATELY AND CALL THE FIRE BRIGADE.

8 – PROBLEMS, CAUSES AND SOLUTIONS

PROBLEM	CAUSE	SOLUTION
Difficulty in lighting the cooker.	Blocked grate.	Clean the grate.
	Moist wood or too thick.	Use smaller sized and more seasoned wood.
	Poor draught.	Clean the ash pan. Remove the warming plate and thoroughly clean the flue gas path and the flue outlet Check the flue pipe: <ul style="list-style-type: none"> • for constrictions • too many curves • bad insulation • section too small
Smoke in the room. Difficulty maintaining the fire. Flame insensitive to draft variations. Puffs while operating.	Poor draught.	Clean the ash pan and all the inspection drawers. Remove the warming plate and thoroughly clean the flue gas path. Clean (or have someone clean) the flue. Check the flue pipe: <ul style="list-style-type: none"> • for constrictions • too many curves • bad insulation • section too small
	No air in the room.	Create an adequate opening for the air.
	Moist wood or too thick.	Use smaller sized and more seasoned wood.
The fuel is burning too quickly, uncontrolled combustion.	Excessive draught.	Reduce draught of the flue outlet by installing a suitable device (e.g., draught regulator).
The handles have warped. Broken components inside the combustion chamber.	Excessive consumption of wood, more than the amount indicated in this manual.	Contact a service centre to restore the appliance for a fee then use the appliance as instructed in this manual and comply with all the supplied instructions.
	Incorrect use of the appliance.	
	No or poor cleaning of the appliance.	

IF THE RECOMMENDED REMEDIES DO NOT SOLVE THE PROBLEM, CONTACT A QUALIFIED TECHNICAL ASSISTANCE SERVICE.

9 – CONDITIONS OF WARRANTY

POINT 1A

Every Thermorossi product is delivered with this warranty certificate. This warranty is to be considered a **conventional guarantee** as defined in art. 133 of Italian Legislative Decree no. 206 dated 6 September 2005 (so-called Consumer Code). This warranty does not in any way affect the rights expressly granted to the consumer concerning the sale of consumer goods as set forth in Italian Legislative Decree no. 206/2005. The consumer is therefore always entitled to exercise these rights with the seller, under the terms and conditions established by the aforementioned legislative decree and by this conventional guarantee.

This warranty is valid only in the case where the product is purchased for domestic uses (i.e. the subject is a consumer as defined in art. 3 paragraph 1, point A of Italian legislative decree 206/2005) and, in any case, not for business or professional purposes. Barring the cases provided for by law, it is the responsibility of the purchaser to demonstrate any product defects and should such product be found to be fully functional, the warranty will be considered inapplicable. The warranty is valid only if the product is installed, used and serviced in accordance with all the instructions provided in the use, maintenance and installation guide delivered with the product.

This warranty certificate is valid solely for the parts mentioned herein.

The warranty is valid for 24 months for the product, excluding the components expressly indicated in point 1C herein. Thermorossi is therefore not responsible for demonstrating the full functionality of the system to which the product is connected, which remains the customer's responsibility. The warranty is subject to the limits and exclusions specified in this warranty certificate and exclusively under the conditions stated herein. In any case, for a warranty claim to be taken into consideration, the customer must report the non-conformity to the seller in writing no later than two months from the date of its identification. The warranty is null and void if this deadline is not respected. The purchaser is responsible for demonstrating that this warranty is valid; this can be done by presenting a delivery document issued by the seller or another document (receipt, till receipt or similar...) indicating the name of the seller, the product identification details (e.g. model code) and the date of the sale or delivery date if later.

Therefore, for the warranty to be valid, the above documentation must be kept by the consumer and shown when the product is being inspected/repaired. This warranty is valid solely under the following conditions:

- all product installation or connection operations are carried out by personnel qualified in accordance with law, who must issue an appropriate declaration of conformity attesting that the work has been carried out according to best practices and scrupulously following the instructions provided in the use, maintenance and installation guide delivered with the product and the regulations regarding systems and safety.
- all operations involving the use of the product, as well as periodic maintenance, must be carried out according to the instructions and indications provided in the use, maintenance and installation guide delivered with the product.
- all repairs to the product must be carried out by personnel of Thermorossi S.p.A. authorised service centres;
- only original Thermorossi spare parts, accessories and consumables must be used.

The warranty (if present) on the **vitrified body** lasts 8 years from the invoice date.

The warranty (if present) on the **standard wet body** lasts 4 years from the invoice date.

Both the warranty on the vitrified body and that on the standard wet body, if present, only cover the internal surface of the combustion chamber in contact with combustion gases, notwithstanding the limits and exclusions listed in this warranty certificate and exclusively in the conditions hereby reported. It shall not apply if the product was not installed by a qualified technician who has verified that all characteristics of the system are suitable. Such characteristics must comply with the legislation on safety and systems. It shall not apply if the product is connected to a system that may cause corrosion, deposits or breakage due to stray currents, condensation, water aggressiveness or acidity, improper descaling treatments, lack of water, sludge or limescale deposits. Failing to connect the system circulating pump to the specific terminal block in the generator causes the warranty to be immediately declared null and void. The system must necessarily guarantee a return water temperature exceeding 55°C.

POINT 1B

Components damaged by causes and/or events external to the product are excluded from this warranty.

The warranty does not apply to damage caused by: excessive or insufficient flue outlet draught, lack of maintenance, failure to clean the product, atmospheric and chemical agents, corrosion of any type and/or nature, fuel overloads, fire, cleaning, tampering with the product, parts damaged due to overheating caused by a lack of maintenance or excess fuel load.

POINT 1C

The following components are excluded from the warranty: door ceramic glass, majolica tile parts, refractory materials, painted or galvanised parts, enamelled parts, gaskets, knobs, handles, thermometers and consumables in general. Warranty replacement does not imply any resetting of the conventional guarantee or its extension. Colour variations on the majolica tiles and the presence of crazing or spotting are not a reason for claims because they are natural characteristics of the materials themselves. Parts found to be defective due to negligence or careless use, damage during transport, incorrect maintenance, or incorrect installation, are not covered by the warranty.

POINT 2A

The technical assistance centre will take appropriate action as soon as possible in the event of failure of the product to function. In this regard, no compensation shall be due for damage or problems following forced inactivity of the product. Repairs or replacements carried out under this conventional guarantee do not imply any resetting of the conventional guarantee or its extension. Thermorossi will repair the product if possible and this is not too costly for the company. The product will only be replaced if it is objectively impossible to repair it and its replacement is not too costly. The product will not be replaced if external factors have caused evident malfunctions. For the purposes of this conventional guarantee, replacement of the product shall be considered too costly if it entails unreasonable expenses compared to its repair, taking into account the estimated value of the product without the defect, the seriousness of the non-conformity and the possibility of repairs being carried out without significantly inconveniencing the consumer. If technical assistance is provided by the personnel of the technical assistance centres at the customer's request, and such assistance is provided outside the warranty (e.g. because the warranty is not valid, because the customer has not sent the warranty certificate in the set times, or because the part is excluded from this warranty), the costs of such assistance will be charged in full to the customer. These costs include:

Call-out fee, the cost of labour and any parts to be replaced. These costs will be of a reasonable amount and the customer can ask the assistance centre for an indication of the amounts in advance. In any case, it should be noted that requests for assistance "under warranty" which, based on the report and analysis carried out by the assistance centre, are the result of tampering, negligence or non-compliant installation, lack of cleaning or in any case not falling within the scope of this conventional guarantee, will entail:

Call-out fee, the cost of labour and any parts to be replaced. These costs will be of a reasonable amount and the customer can ask the assistance centre for an indication of the amounts in advance.

POINT 2B

Thermorossi S.p.A. declines liability for any damage directly or indirectly caused to persons, animals or property, due to or related to installation that does not comply in full with current regulations and/or installation, use and maintenance that does not comply in full with all the instructions contained in the installation, use and maintenance guide delivered with the product.



THERMOROSSI 

Fire Lovers

THERMOROSSI S.p.A.

Via Grumolo, 4 (Z.I.) 36011 Arsiero (VI) - ITALY

Fax 0445.741657 - www.thermorossi.com - info@thermorossi.it